

## Type SLK

Conductance Sensor for phase und product-monitoring

### Basic Features

- ▶ Materials:
  - Test prod: 316L/1.4404/1.45771
  - Isolator: PEEK (FDA)
  - Case parts : 1.4305/1.4301
  - Nozzle G1/2" A/F22: 1.4305/1.4301
- ▶ Settings via PC-Software and Y-programming interface
- ▶ welding sleeve-system with modular process connections
- ▶ Aseptic measuring point
- ▶ Wetting parts made of peek
- ▶ FDA, EHEDG-conformal



### Technical features

- ▶ Supply voltage  $U_b = 24V \pm 20\%$  (18...32VDC)
- ▶ Measuring range:  $0\mu S/cm - 15000\mu S/cm$
- ▶ Output-signal: PNP; 18-32V; Permissible load 0 Ohm at 24V; 35mA or alternatively Analogous 4-20mA; load  $\leq 680$  Ohm
- ▶ Response time  $< 0.5s$
- ▶ Ambient temperature:  $-10... +60^\circ C$
- ▶ Process temperature:  $0...+100^\circ C$   
Neck-Pipe-Version:  $0...+125^\circ C$
- ▶ Storage temperature:  $-20... +70^\circ C$
- ▶ CIP-/SIP Cleansing:  $0...+150^\circ C$  (30 min.)
- ▶ Working pressure: 10bar max.
- ▶ Accuracy: 5% from measured value
- ▶ Integrated temperature compensation
- ▶ Protection class: IP 68
- ▶ Torque max.: 5...10 Nm

### Favoured fields of application are e.g:

- ▶ Conductive Conductance for product monitoring and phase separation in the food and pharmaceutical industry

Visualization via PC-USB interface Software incl. for readout and parameterization of SLK



## Type SLK

### Structure and mode of action

The conductivity sensor SLK based on a conductive measuring system. Conductive means that an AC voltage between a pair of electrodes is applied in this case consisting of a sensor tip and weld.

The current between the electrodes can be measured and depends on the electrical conductivity of the process fluid..

Because the conductivity of the medium is affected by temperature, it is imperative to take the media temperature.

For this purpose, in the sensor tip a fast-response temperature sensor is built, that is recording the temperature and enables a so-called temperature compensation.

From the measured conductivity as well as from the measured fluid temperature, the microprocessor which is integrated in the sensor calculates the conductivity of the medium for a reference temperature of 25 ° C.

By using the software, the processes are visible and documentable and can be adjusted to the on and off points and in the scaling of the analog output.

The integration of the device in the process is done with welding sleeves or with our modular

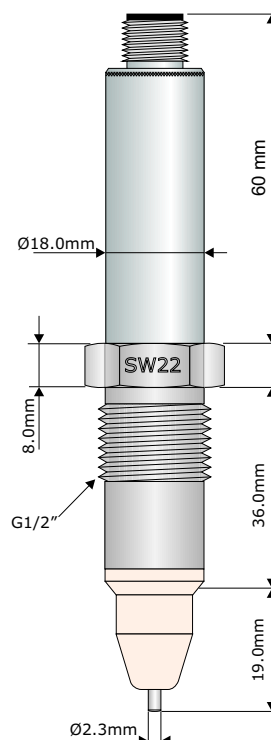

### Accessories (Parameterization)

For parameterization, both the PC USB interface SMW-PA-M12 and the programming adapter ST-M12-Y-AD is required.

#### SMW-PA-M12

PC-USB-Interface incl. Software for reading out and parameterizing

#### ST-M12-Y-AD

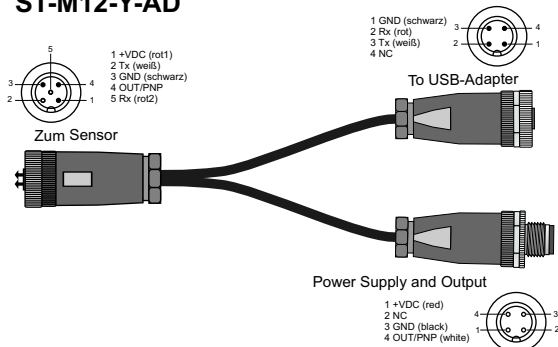

### Pin assignment

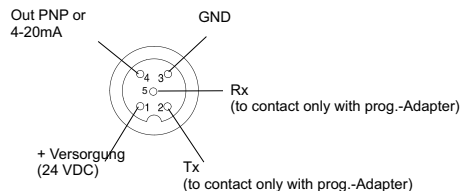

### Order Code SLK

High-Grade-Steel Connecting Head			SLK- 11 -
Plug M12			11
Version			
Standard	Standard		S
Neck pipe	Neck pipe		H