



# VIPA System SLIO



**FM | 050-1BA10 | Manual**

HB300E\_FM | RE\_050-1BA10 | Rev. 10/30

July 2010

## **Copyright © VIPA GmbH. All Rights Reserved.**

This document contains proprietary information of VIPA and is not to be disclosed or used except in accordance with applicable agreements.

This material is protected by the copyright laws. It may not be reproduced, distributed, or altered in any fashion by any entity (either internal or external to VIPA), except in accordance with applicable agreements, contracts or licensing, without the express written consent of VIPA and the business management owner of the material.

For permission to reproduce or distribute, please contact:  
VIPA, Gesellschaft für Visualisierung und Prozessautomatisierung mbH  
Ohmstraße 4, D-91074 Herzogenaurach, Germany  
Tel.: +49 (91 32) 744 -0  
Fax.: +49 9132 744 1864  
EMail: [info@vipa.de](mailto:info@vipa.de)  
<http://www.vipa.de>

## **Note**

Every effort has been made to ensure that the information contained in this document was complete and accurate at the time of publishing. Nevertheless, the authors retain the right to modify the information. This customer document describes all the hardware units and functions known at the present time. Descriptions may be included for units which are not present at the customer site. The exact scope of delivery is described in the respective purchase contract.

## **CE Conformity**

Hereby, VIPA GmbH declares that the products and systems are in compliance with the essential requirements and other relevant provisions of the following directives:

- 2004/108/EC Electromagnetic Compatibility Directive
- 2006/95/EC Low Voltage Directive

Conformity is indicated by the CE marking affixed to the product.

## **Conformity Information**

For more information regarding CE marking and Declaration of Conformity (DoC), please contact your local VIPA customer service organization.

## **Trademarks**

VIPA, SLIO, System 100V, System 200V, System 300V, System 300S, System 400V, System 500S and Commander Compact are registered trademarks of VIPA Gesellschaft für Visualisierung und Prozessautomatisierung mbH.

SPEED7 is a registered trademark of profichip GmbH.

SIMATIC, STEP, SINEC, S7-300 and S7-400 are registered trademarks of Siemens AG.

Microsoft und Windows are registered trademarks of Microsoft Inc., USA.

Portable Document Format (PDF) and Postscript are registered trademarks of Adobe Systems, Inc.

All other trademarks, logos and service or product marks specified herein are owned by their respective companies.

## **Information product support**

Contact your local VIPA Customer Service Organization representative if you wish to report errors or questions regarding the contents of this document. If you are unable to locate a customer service center, contact VIPA as follows:

VIPA GmbH, Ohmstraße 4, 91074 Herzogenaurach, Germany

Telefax: +49 9132 744 1204  
EMail: [documentation@vipa.de](mailto:documentation@vipa.de)

## **Technical support**

Contact your local VIPA Customer Service Organization representative if you encounter problems with the product or have questions regarding the product. If you are unable to locate a customer service center, contact VIPA as follows:

VIPA GmbH, Ohmstraße 4, 91074 Herzogenaurach, Germany

Telephone: +49 9132 744 1150/1180 (Hotline)  
EMail: [support@vipa.de](mailto:support@vipa.de)

# Contents

<b>About this manual .....</b>	<b>1</b>
<b>Safety information.....</b>	<b>2</b>
<b>Chapter 1 Basics and Assembly .....</b>	<b>1-1</b>
Safety Information for Users.....	1-2
System conception .....	1-3
Dimensions .....	1-6
Installation .....	1-7
Wiring.....	1-11
Trouble shooting - LEDs.....	1-14
Installation guidelines .....	1-15
General data .....	1-18
<b>Chapter 2 Hardware description .....</b>	<b>2-1</b>
Properties.....	2-2
Structure .....	2-3
Technical Data .....	2-5
<b>Chapter 3 Deployment .....</b>	<b>3-1</b>
Fast introduction.....	3-2
In-/Output area .....	3-5
Parameter data .....	3-7
Counter functions .....	3-10
Counter additional functions .....	3-16
Diagnostic and interrupt .....	3-21



## About this manual

This manual describes the function module FM 050-1BA10 of the system SLIO from VIPA. Here you may find besides of a product overview a detailed description of the function module. You'll receive information about the connection and the deployment of the System SLIO module.

### Overview

#### **Chapter 1: Basics and Assembly**

The focus of this chapter is on the introduction of the VIPA System SLIO. Here you will find the information required to assemble and wire a controller system consisting of System SLIO components.

Besides the dimensions the general technical data of System SLIO will be found.

#### **Chapter 2: Hardware description**

In this chapter the counter module 050-1BA10 of the System SLIO is described. Here every information about the hardware components of the module may be found.

The technical data are at the end of the chapter.

#### **Chapter 3: Deployment**

In this chapter the deployment of the System SLIO counter module 050-1BA10 is described. Here every information required for the deployment may be found.

<b>Objective and contents</b>	This manual describes the System SLIO function module 050-1BA10 from VIPA. It contains a description of the construction, project implementation and usage.
<b>Target audience</b>	The manual is targeted at users who have a background in automation technology.
<b>Structure of the manual</b>	The manual consists of chapters. Every chapter provides a self-contained description of a specific topic.
<b>Guide to the document</b>	The following guides are available in the manual: <ul style="list-style-type: none"><li>• an overall table of contents at the beginning of the manual</li><li>• an overview of the topics for every chapter</li></ul>
<b>Availability</b>	The manual is available in: <ul style="list-style-type: none"><li>• printed form, on paper</li><li>• in electronic form as PDF-file (Adobe Acrobat Reader)</li></ul>
<b>Icons Headings</b>	Important passages in the text are highlighted by following icons and headings:

**Danger!**

Immediate or likely danger.  
Personal injury is possible.

**Attention!**

Damages to property is likely if these warnings are not heeded.

**Note!**

Supplementary information and useful tips.

## Safety information

### Applications conforming with specifications

The System SLIO is constructed and produced for:

- communication and process control
- general control and automation applications
- industrial applications
- operation within the environmental conditions specified in the technical data
- installation into a cubicle



### Danger!

This device is not certified for applications in

- in explosive environments (EX-zone)

### Documentation

The manual must be available to all personnel in the

- project design department
- installation department
- commissioning
- operation



**The following conditions must be met before using or commissioning the components described in this manual:**

- Modification to the process control system should only be carried out when the system has been disconnected from power!
- Installation and modifications only by properly trained personnel
- The national rules and regulations of the respective country must be satisfied (installation, safety, EMC ...)

### Disposal

**National rules and regulations apply to the disposal of the unit!**





## Chapter 1 Basics and Assembly

### Overview

The focus of this chapter is on the introduction of the VIPA System SLIO. Here you will find the information required to assemble and wire a controller system consisting of System SLIO components. Besides the dimensions the general technical data of System SLIO will be found.

### Content

Topic	Page
<b>Chapter 1 Basics and Assembly .....</b>	<b>1-1</b>
Safety Information for Users.....	1-2
System conception .....	1-3
Dimensions .....	1-6
Installation .....	1-7
Wiring.....	1-11
Trouble shooting - LEDs.....	1-14
Installation guidelines .....	1-15
General data .....	1-18

## Safety Information for Users

### Handling of electrostatic sensitive modules

VIPA modules make use of highly integrated components in MOS-Technology. These components are extremely sensitive to over-voltages that can occur during electrostatic discharges.

The following symbol is attached to modules that can be destroyed by electrostatic discharges.



The Symbol is located on the module, the module rack or on packing material and it indicates the presence of electrostatic sensitive equipment.

It is possible that electrostatic sensitive equipment is destroyed by energies and voltages that are far less than the human threshold of perception. These voltages can occur where persons do not discharge themselves before handling electrostatic sensitive modules and they can damage components thereby, causing the module to become inoperable or unusable.

Modules that have been damaged by electrostatic discharges can fail after a temperature change, mechanical shock or changes in the electrical load.

Only the consequent implementation of protection devices and meticulous attention to the applicable rules and regulations for handling the respective equipment can prevent failures of electrostatic sensitive modules.

### Shipping of modules

Modules must be shipped in the original packing material.

### Measurements and alterations on electrostatic sensitive modules

When you are conducting measurements on electrostatic sensitive modules you should take the following precautions:

- Floating instruments must be discharged before use.
- Instruments must be grounded.

Modifying electrostatic sensitive modules you should only use soldering irons with grounded tips.



### Attention!

Personnel and instruments should be grounded when working on electrostatic sensitive modules.

## System conception

### Overview

System SLIO is a modular automation system for assembly on a 35mm mounting rail. By means of the peripheral modules with 2, 4 or 8 channels this system may properly be adapted matching to your automation tasks.

The wiring complexity is low, because the supply of the DC 24V power section is integrated to the backplane bus and defective modules may be replaced with standing wiring.

By deployment of the power modules in contrasting colors within the system, further isolated areas may be defined for the DC 24V power section supply, respectively the electronic power supply may be extended with 2A.

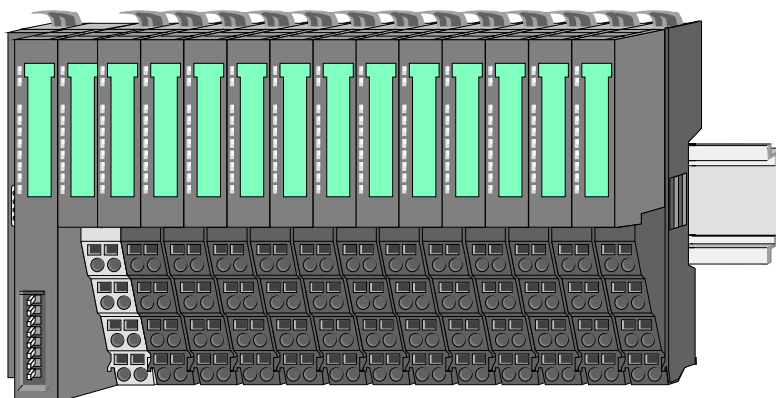

### Components

The System SLIO consists of the following components:

- Bus coupler
- Periphery modules
- Power modules
- Accessories

### Bus coupler

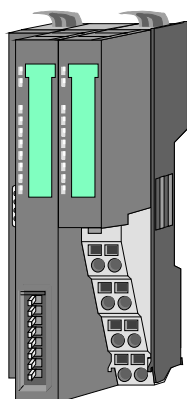

With a bus coupler bus interface and power module is integrated to one casing. With the bus interface you get access to a subordinated bus system.

Via the integrated power module for power supply the bus interface is supplied as well as the electronic of the connected periphery modules.

The DC 24 power section supply for the linked periphery modules is established via a further connection.

By installing of up to 64 periphery modules at the bus coupler, these are electrically connected, this means these are assigned to the backplane bus, the electronic modules are power supplied and each periphery module is connected to the DC 24V power section supply.

**Periphery modules** Each periphery module consists of a *terminal* and an *electronic* module.

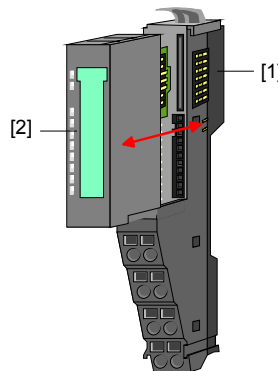
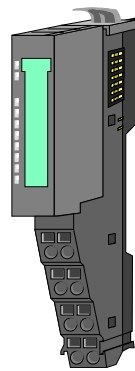

- [1] Terminal module
- [2] Electronic module

**Terminal module**

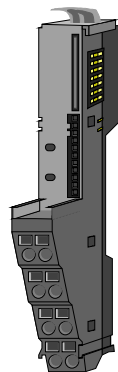

The *terminal module* serves to carry the electronic module, contains the backplane bus with power supply for the electronic, the DC 24V power section supply and the staircase-shaped terminal for wiring.

Additionally the terminal module has a locking system for fixing at a mounting rail.

By means of this locking system your SLIO system may be assembled outside of your switchgear cabinet to be later mounted there as whole system.

**Electronic module**

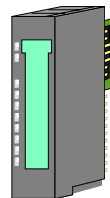

The functionality of a SLIO periphery module is defined by the *electronic module*, which is mounted to the terminal module by a save sliding mechanism.

With an error the defective module may be exchanged for a functional module with standing installation.

By an integrated coding only the modules may be plugged, which may be combined.

At the front side there are LEDs for status indication.

For simple wiring each module shows a corresponding connection diagram at the front and at the side.

**Power module**

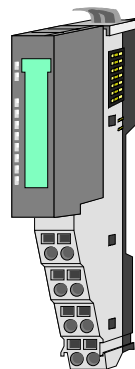

In the system SLIO the power supply is established by power modules. These are either integrated to the bus coupler or may be installed between the periphery modules. Depending on the power module isolated areas of the DC 24V power section supply may be defined respectively the electronic power supply may be extended with 2A.

For better recognition the color of the power modules are contrasting to the periphery modules.

## Accessories

### Shield bus carrier



The shield bus carrier serves to carry the shield bus to connect cable shields.

Shield bus carriers, shield bus and shield fixings are not in the scope of delivery. They are only available as accessories.

The shield bus carrier is mounted underneath the terminal of the terminal module.

With a flat mounting rail for adaption to a flat mounting rail you may remove the spacer of the shield bus carrier.

### Bus cover

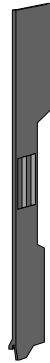

With each bus coupler, to protect the backplane bus connectors, there is a mounted bus cover in the scope of delivery. You have to remove the bus cover of the bus coupler before mounting a SLIO module.

For the protection of the backplane bus connector you should always mount the bus cover at the last module of your system again.

# Dimensions

## Dimensions bus coupler



## Dimensions periphery module

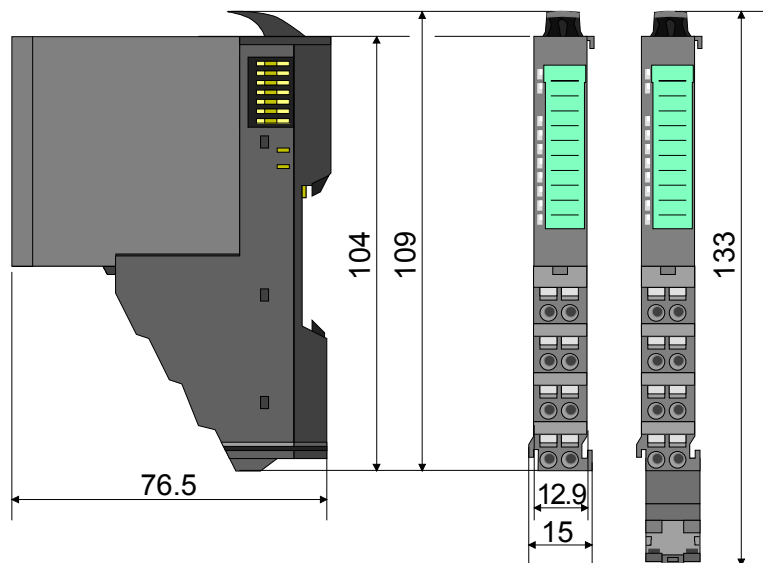

## Dimensions electronic module

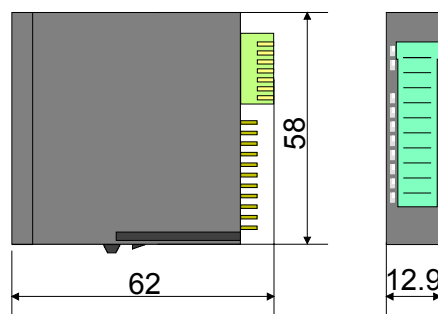

Dimensions in mm

# Installation

## Functional principle

### Mounting terminal module

There is a locking lever at the top side of the terminal module. For mounting and de-mounting this locking lever is to turn upwards until this engages audible.

Now the module may be pulled forward.

For mounting plug the module to the module installed before and push the module to the mounting rail guided by the strips at the upper and lower side of the module.

The module is fixed to the mounting rail by pushing downwards the locking lever.

The modules may either separately be mounted to the mounting rail or as block. Here is to be considered that each locking lever is opened.

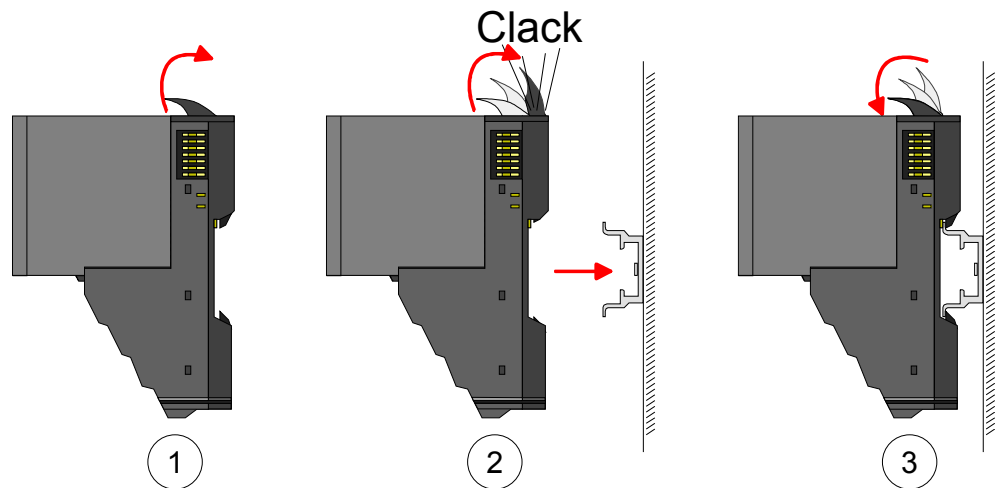

### Mounting electronic module

For mounting between 2 modules and for the exchange of a defective electronic module, the electronic module may be pulled forward after pressing the unlocking lever at the lower side of the module.

For installation plug the electronic module guided by the strips at the lower side until this engages audible to the terminal module.

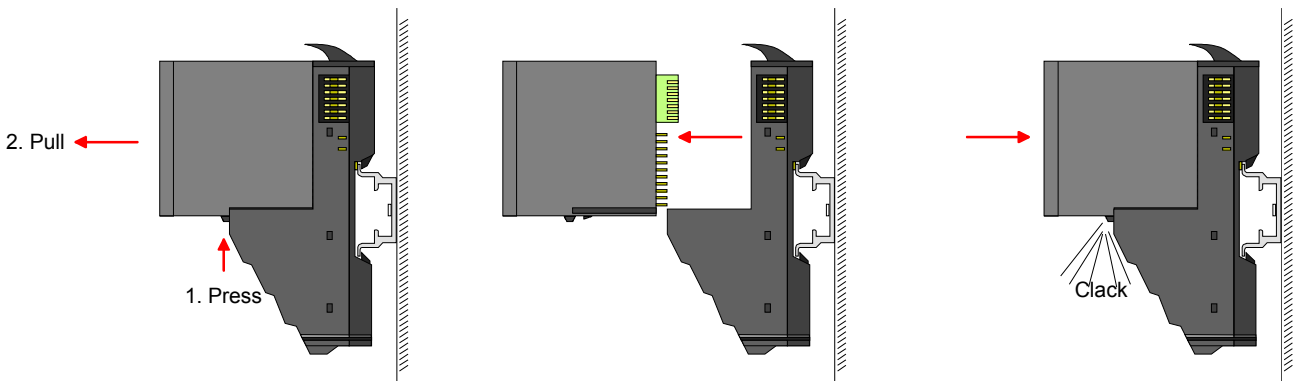

**Mounting Proceeding**

The modules were directly be mounted to the mounting rail and so connected to the backplane bus and the power supply for the electronic and power section.

Up to 64 modules may be mounted. Please consider here that the sum current of the electronic power supply does not exceed the maximum value of 3A. By means of the power module 007-1AB10 the current of the electronic power supply may be expanded with 2A. More about this may be found at "Wiring".

**Mounting mounting rail**

- Mount the mounting rail! Please consider that a clearance from the middle of the mounting rail of at least 80mm above and 60mm below, respectively 80mm by deployment of shield bus carriers, exist.

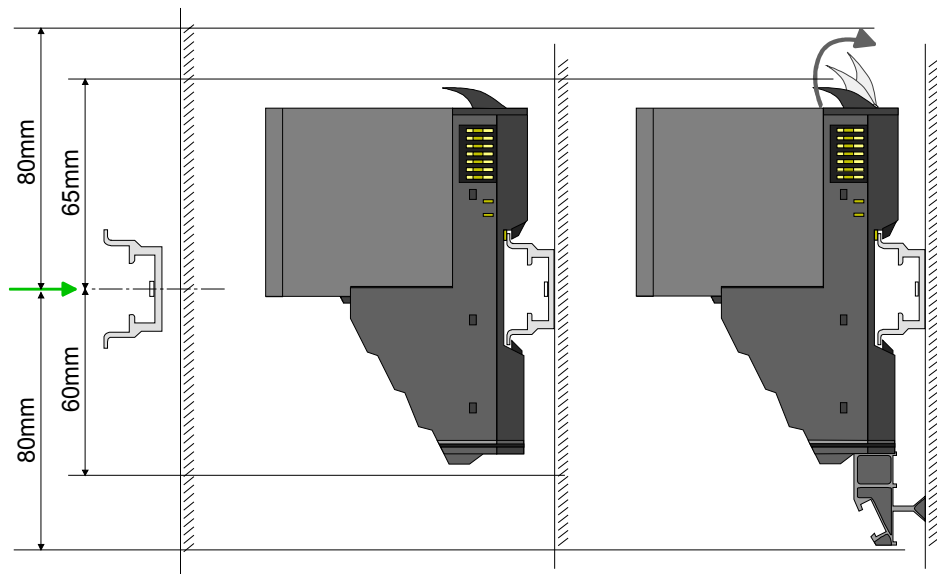

**Mounting Head module (e.g. bus coupler)**

- Start at the left side with the head module (e.g. bus coupler). For this turn both locking lever upwards, put the head module to the mounting rail and turn both locking lever downwards.
- Before mounting the periphery modules you have to remove the bus cover at the right side of the Head module by pulling it forward. Keep the cover for later mounting.

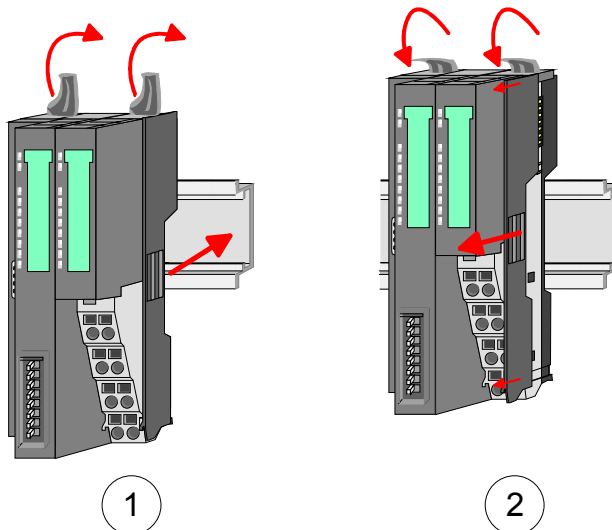



**Mounting  
periphery module**

- Mount the periphery modules you want.

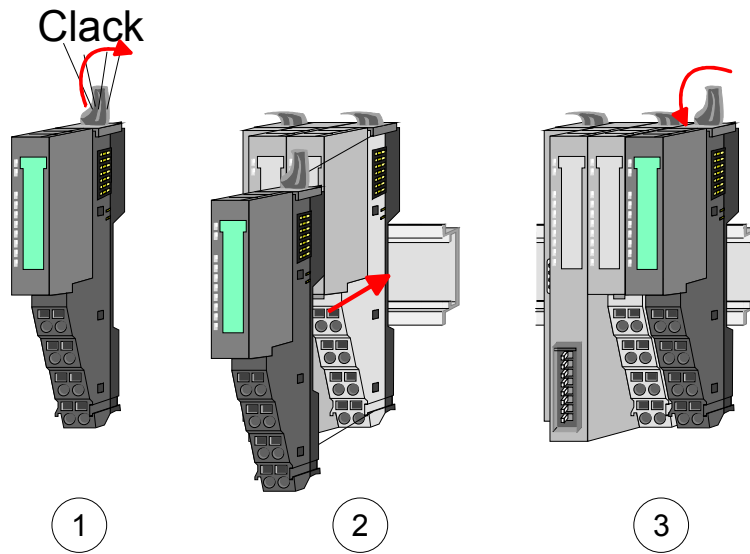

**Mounting the  
bus cover**

- After mounting the whole system, to protect the backplane bus connectors the bus cover may now be mounted at the last module

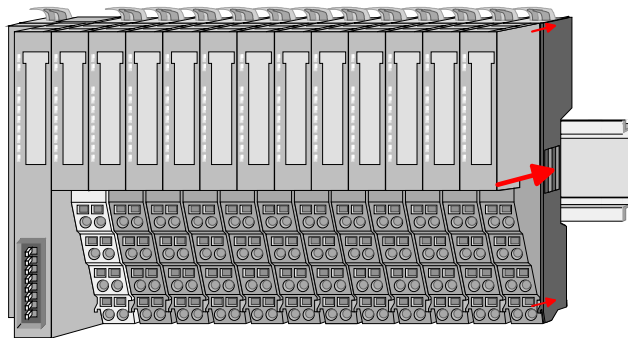

**Mounting  
shield bus carrier**

The shield bus carrier (available as accessory) serves to carry the shield bus to connect cable shields. The shield bus carrier is mounted underneath the terminal of the terminal module. With a flat mounting rail for adaption to a flat mounting rail you may remove the spacer of the shield bus carrier.

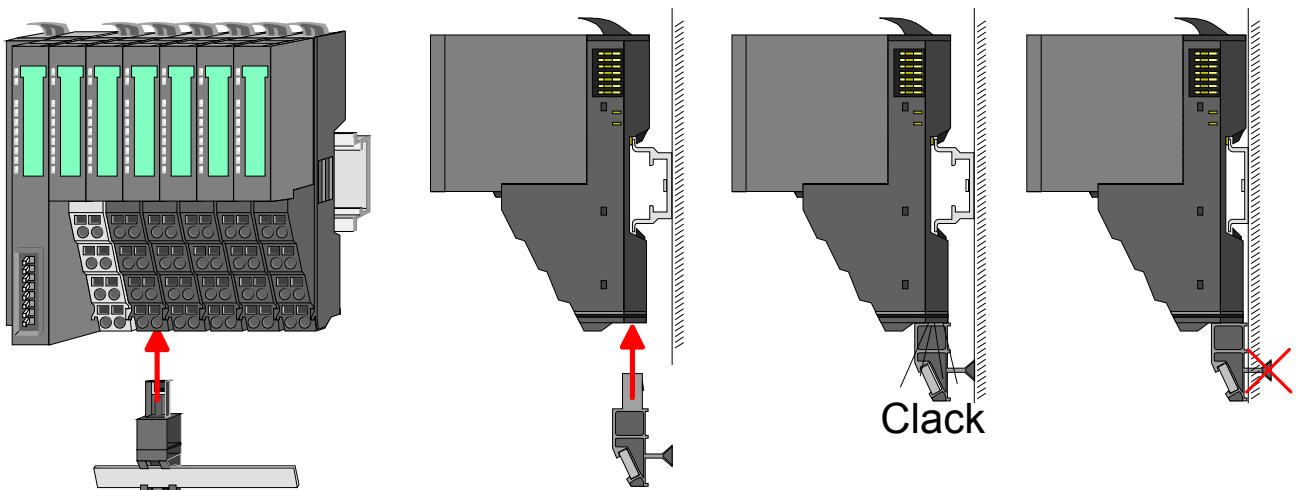

**Mounting between 2 modules**

With the mounting of a SLIO module respectively of a group of SLIO modules between two modules for mounting reasons you have always to remove the electronic module of the just mounted right module. After that it may be plugged again.

To mount the module put it to the gap between the both modules and push it, guided by the stripes at both sides, to the mounting rail.

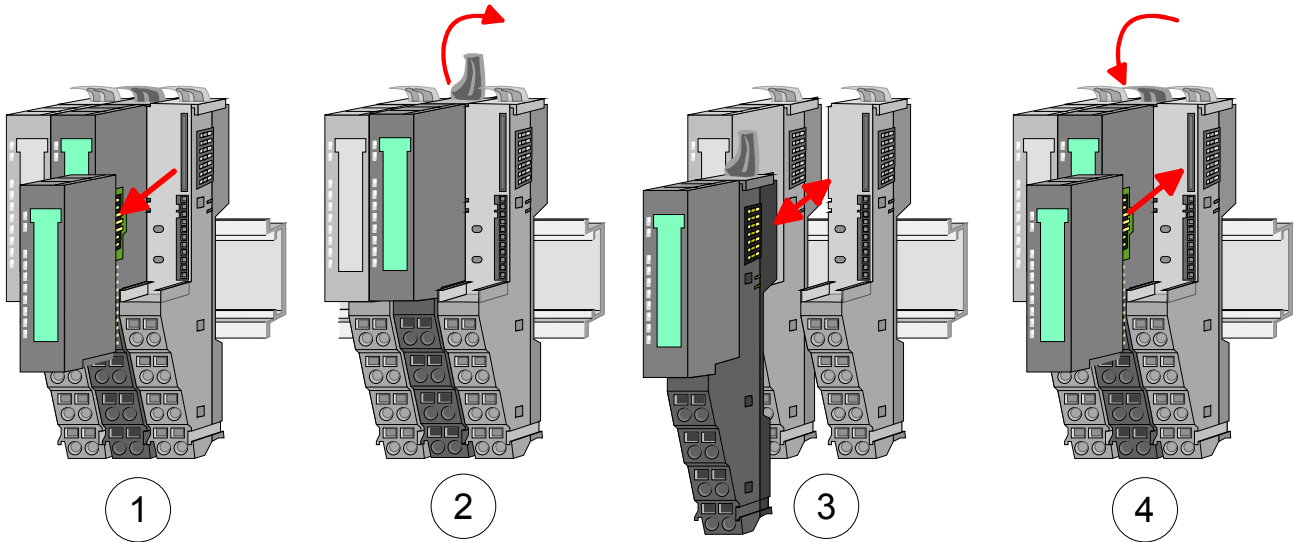

**1 module group between 2 modules**

With mounting respectively de-mounting of a module group you also have to remove the electronic module of the just mounted right module! After mounting it may be plugged again.

For mounting respectively de-mounting the locking lever of the modules of the block must be turned upwards.

To mount the group of modules put them to the gap between the both modules and push it, guided by the stripes at both sides, to the mounting rail.

After mounting the block turn each locking lever of the modules downwards.

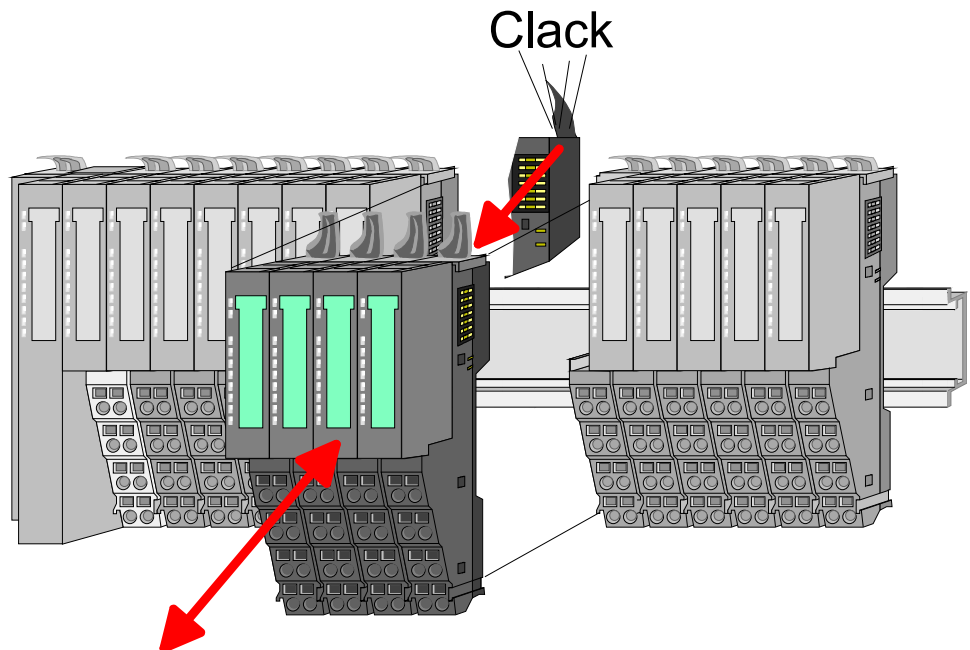

# Wiring

## Standard wiring

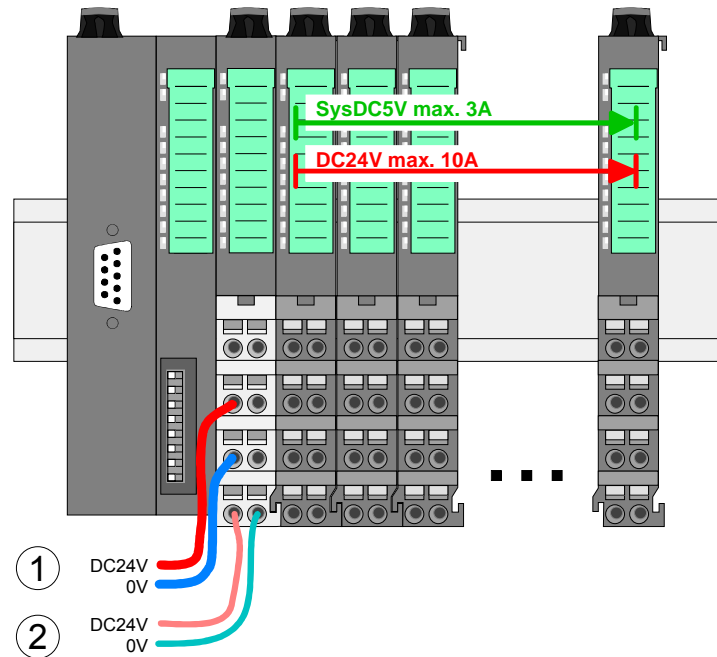

- [1] DC 24V Power section supply I/O area
- [2] DC 24V for Electronic power supply bus coupler and I/O area



### Note!

Power section and electronic power section supply are internally protected against higher voltage by fuses. The fuses are within the power module. If one fuse released, its electronic module must be exchanged! It is recommended to externally protect the power section supply with a fast 10A fuse and the electronic power supply with a fast 4A fuse.

### State of the electronic power supply via LEDs

After PowerON of the System SLIO the LEDs RUN respectively MF get on so far as the sum current does not exceed 3A. With a sum current greater than 3A the LEDs may not be activated. Here the power module with the order number 007-1AB10 is to be placed between the peripheral modules. More concerning this may be found at the following page.

**Deployment of the power modules**

If the 10A for the power section supply is no longer sufficient, you may use the power module from VIPA with the order number 007-1AB00. So you have also the possibility to define isolated groups.

The power module with the order number 007-1AB10 is to be used if the 3A for the electronic power supply at the backplane bus is no longer sufficient.

Additionally you get an isolated group for the DC 24V power section supply with 10A.

By placing the power module 007-1AB10 at the following backplane bus modules may be placed with a sum current of max. 2A. Afterwards the power module 007-1AB10 is to be placed again.

Power module 007-1AB00

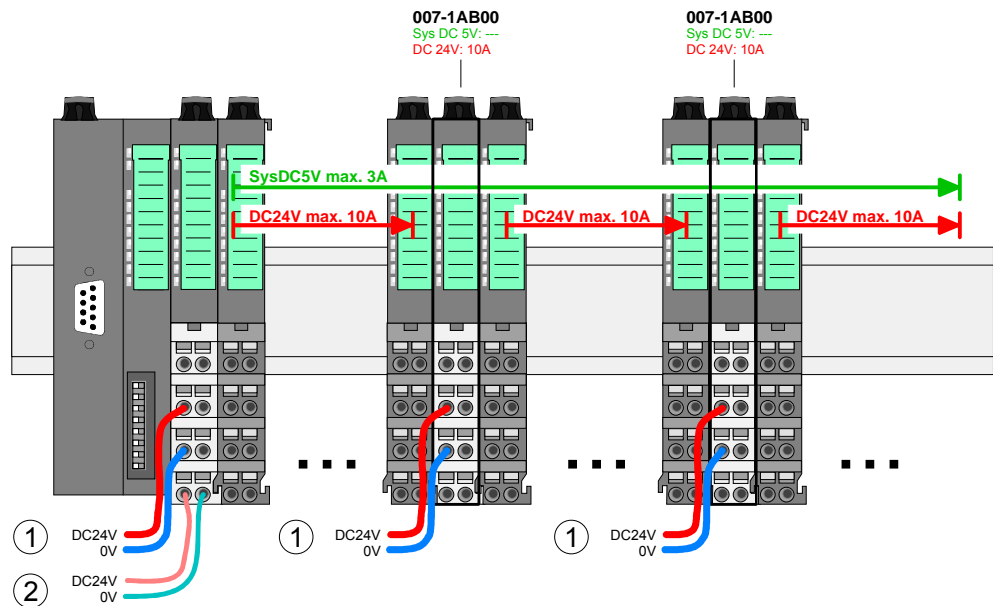

Power module 007-1AB10

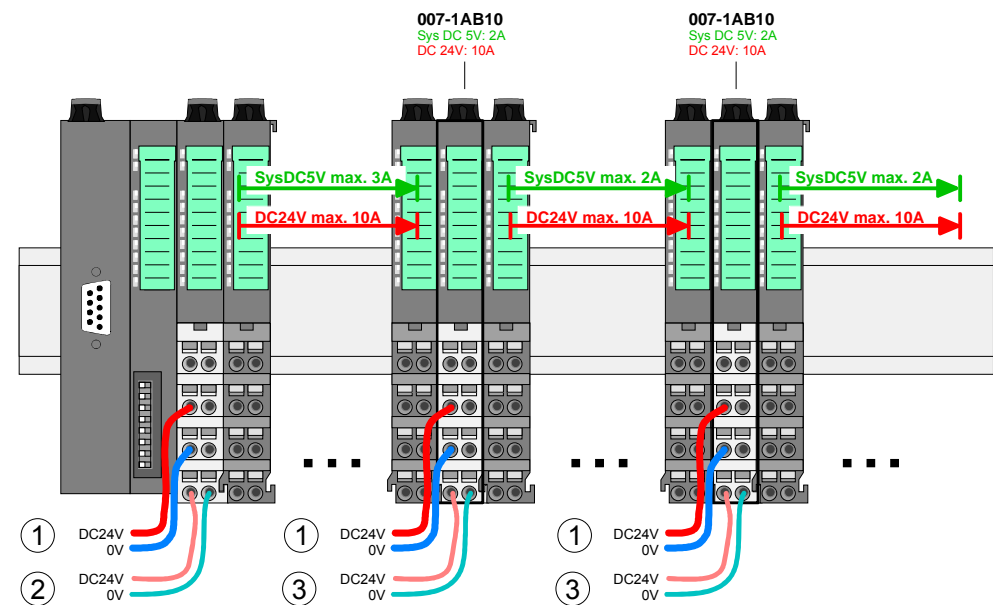

- [1] DC 24V Power section supply I/O area (max. 10A)
- [2] DC 24V for Electronic power supply bus coupler and I/O area
- [3] DC 24V for Electronic power supply I/O area

**Shield attachment** To attach the shield the mounting of shield bus carriers are necessary. The shield bus carrier (available as accessory) serves to carry the shield bus to connect cable shields.

The shield bus carrier is mounted underneath the terminal of the terminal module. With a flat mounting rail for adaption to a flat mounting rail you may remove the spacer of the shield bus carrier.

After mounting the shield bus carrier with the shield bus, the cables with the accordingly stripped cable screen may be attached and fixed by the shield clamp.

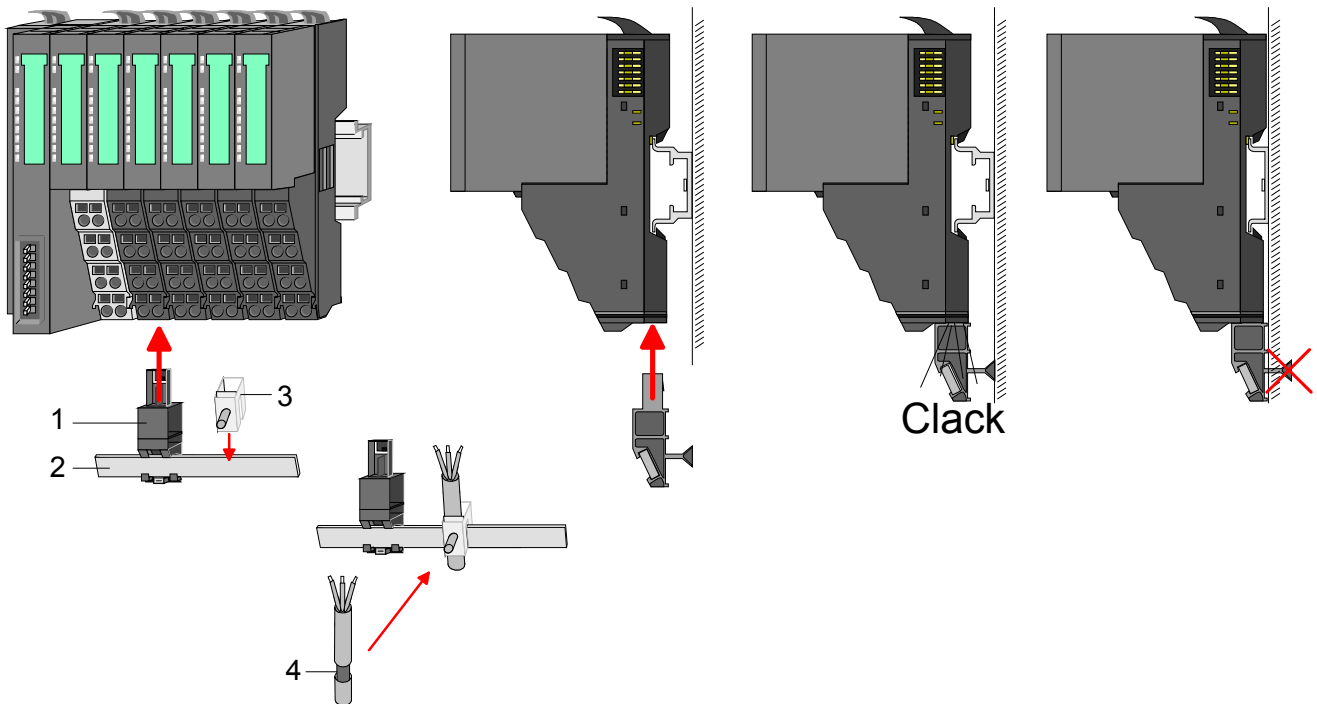

- [1] Shield bus carrier
- [2] Shield bus
- [3] Shield clamp
- [4] Cable shield

## Trouble shooting - LEDs

### General

Each module has the LEDs RUN and MF on its front side. Errors or incorrect modules may be located by means of these LEDs.  
 In the following illustrations flashing LEDs are marked by ☼.

### Sum current of the electronic power supply exceeded

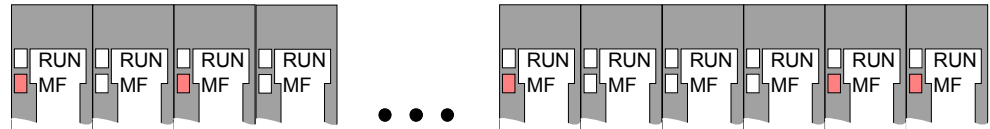

*Behavior:* After PowerON the RUN LED of each module is off and the MF LED of each module is sporadically on.

*Reason:* The maximum current for the electronic power supply is exceeded.

*Remedy:* As soon as the sum current of the electronic power supply is exceeded, always place the power module 007-1AB10. More concerning this may be found above at "Wiring".

### Error in configuration

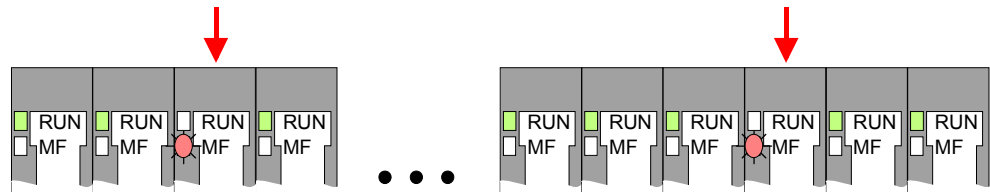

*Behavior:* After PowerON the MF LED of one module respectively more modules flashes. The RUN LED remains off.

*Reason:* At this position a module is placed, which does not correspond to the configured module.

*Remedy:* Match configuration and hardware structure.

### Module failure

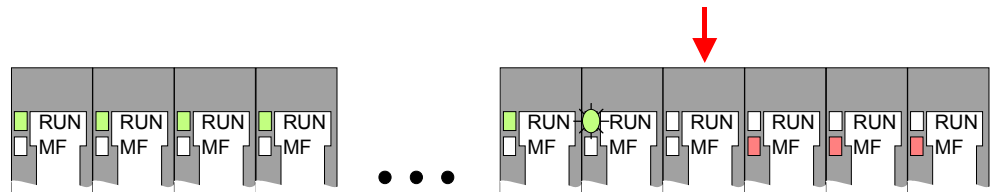

*Behavior:* After PowerON the RUN LED flashes at one module. The RUN and MF LEDs of the following module are off. With all following modules the MF LED is on and the RUN LED is off.

*Reason:* The module on the right of the flashing module is defective.

*Remedy:* Replace the defective module.

## Installation guidelines

<b>General</b>	<p>The installation guidelines contain information about the interference free deployment of System SLIO. There is the description of the ways, interference may occur in your control, how you can make sure the electromagnetic digestibility (EMC), and how you manage the isolation.</p>
<b>What means EMC?</b>	<p>Electromagnetic digestibility (EMC) means the ability of an electrical device, to function error free in an electromagnetic environment without being interferenced res. without interfering the environment.</p> <p>All System SLIO components are developed for the deployment in hard industrial environments and fulfill high demands on the EMC. Nevertheless you should project an EMC planning before installing the components and take conceivable interference causes into account.</p>
<b>Possible interference causes</b>	<p>Electromagnetic interferences may interfere your control via different ways:</p> <ul style="list-style-type: none"><li>• Fields</li><li>• I/O signal conductors</li><li>• Bus system</li><li>• Current supply</li><li>• Protected earth conductor</li></ul> <p>Depending on the spreading medium (lead bound or lead free) and the distance to the interference cause, interferences to your control occur by means of different coupling mechanisms.</p> <p>One differs:</p> <ul style="list-style-type: none"><li>• galvanic coupling</li><li>• capacitive coupling</li><li>• inductive coupling</li><li>• radiant coupling</li></ul>

**Basic rules for EMC**

In the most times it is enough to take care of some elementary rules to guarantee the EMC. Please regard the following basic rules when installing your PLC.

- Take care of a correct area-wide grounding of the inactive metal parts when installing your components.
  - Install a central connection between the ground and the protected earth conductor system.
  - Connect all inactive metal extensive and impedance-low.
  - Please try not to use aluminum parts. Aluminum is easily oxidizing and is therefore less suitable for grounding.
- When cabling, take care of the correct line routing.
  - Organize your cabling in line groups (high voltage, current supply, signal and data lines).
  - Always lay your high voltage lines and signal res. data lines in separate channels or bundles.
  - Route the signal and data lines as near as possible beside ground areas (e.g. suspension bars, metal rails, tin cabinet).
- Proof the correct fixing of the lead isolation.
  - Data lines must be laid isolated.
  - Analog lines must be laid isolated. When transmitting signals with small amplitudes the one sided laying of the isolation may be favorable.
  - Lay the line isolation extensively on an isolation/protected earth conductor rail directly after the cabinet entry and fix the isolation with cable clamps.
  - Make sure that the isolation/protected earth conductor rail is connected impedance-low with the cabinet.
  - Use metallic or metalized plug cases for isolated data lines.
- In special use cases you should appoint special EMC actions.
  - Wire all inductivities with erase links, which are not addressed by the System SLIO modules.
  - For lightening cabinets you should prefer incandescent lamps and avoid luminescent lamps.
- Create a homogeneous reference potential and ground all electrical operating supplies when possible.
  - Please take care for the targeted employment of the grounding actions. The grounding of the PLC is a protection and functionality activity.
  - Connect installation parts and cabinets with the System SLIO in star topology with the isolation/protected earth conductor system. So you avoid ground loops.
  - If potential differences between installation parts and cabinets occur, lay sufficiently dimensioned potential compensation lines.



**Isolation of conductors**

Electrical, magnetically and electromagnetic interference fields are weakened by means of an isolation, one talks of absorption.

Via the isolation rail, that is connected conductive with the rack, interference currents are shunt via cable isolation to the ground. Hereby you have to make sure, that the connection to the protected earth conductor is impedance-low, because otherwise the interference currents may appear as interference cause.

When isolating cables you have to regard the following:

- If possible, use only cables with isolation tangle.
- The hiding power of the isolation should be higher than 80%.
- Normally you should always lay the isolation of cables on both sides. Only by means of the both-sided connection of the isolation you achieve high quality interference suppression in the higher frequency area.  
Only as exception you may also lay the isolation one-sided. Then you only achieve the absorption of the lower frequencies. A one-sided isolation connection may be convenient, if:
  - the conduction of a potential compensating line is not possible
  - analog signals (some mV res.  $\mu$ A) are transferred
  - foil isolations (static isolations) are used.
- With data lines always use metallic or metalized plugs for serial couplings. Fix the isolation of the data line at the plug rack. Do not lay the isolation on the PIN 1 of the plug bar!
- At stationary operation it is convenient to strip the insulated cable interruption free and lay it on the isolation/protected earth conductor line.
- To fix the isolation tangles use cable clamps out of metal. The clamps must clasp the isolation extensively and have well contact.
- Lay the isolation on an isolation rail directly after the entry of the cable in the cabinet. Lead the isolation further on to the System SLIO module and **don't** lay it on there again!

**Please regard at installation!**

At potential differences between the grounding points, there may be a compensation current via the isolation connected at both sides.

Remedy: Potential compensation line

## General data

Conformity and approval		
Conformity		
CE	73/23/EWG	Low-voltage directive
Approval		
UL	UL 508	Approval for USA and Canada
others		
RoHs	-	Product is unleaded

Protection of persons and device protection		
Type of protection	-	IP20
Electrical isolation		
to the field bus	-	electrically isolated
to the process level	-	electrically isolated
Insulation resistance	EN 61131-2	-
Insulation voltage to reference earth		
Inputs / outputs	-	AC / DC 50V, test voltage AC 500V
Protective measures	-	against short circuit

Environmental conditions to EN 61131-2		
Climatic		
Storage / transport	EN 60068-2-14	-25...+70°C
Operation		
Horizontal installation	EN 61131-2	0...+60°C
Vertical installation	EN 61131-2	0...+60°C
Air humidity	EN 60068-2-30	RH1 (without condensation, rel. humidity 10 ... 95%)
Pollution	EN 61131-2	Degree of pollution 2
<b>Mechanical</b>		
Oscillation	EN 60068-2-6	1G
Shock	EN 60068-2-27	15G

Mounting conditions		
Mounting place	-	In the control cabinet
Mounting position	-	Horizontal and vertical

EMC	Standard	Comment	
Emitted interference	EN 61000-6-4	Class A (Industry area)	
Noise immunity zone B	EN 61000-6-2	Industry area	
		EN 61000-4-2	ESD Degree of severity 3, i.e. 8kV at air discharge, 4kV at contact discharge
		EN 61000-4-3	HF irradiation (casing) 80MHz ... 1000MHz, 10V/m 80% AM (1kHz)
		EN 61000-4-6	HF conducted 150kHz ... 80MHz, 10V/m 80% AM (1kHz)
		EN 61000-4-4	Burst, degree of severity 3
	EN 61000-4-5	Surge, degree of severity 3	

## Chapter 2 Hardware description

### Overview

In this chapter the counter module 050-1BA10 of the System SLIO is described. Here every information about the hardware components of the module may be found.

The technical data are at the end of the chapter.

### Content

Topic	Page
<b>Chapter 2 Hardware description.....</b>	<b>2-1</b>
Properties.....	2-2
Structure .....	2-3
Technical Data .....	2-5

## Properties

### Features

- 1 counter 32bit (AB) invertible, DC 5V (difference signal)
- Counting frequency max. 2MHz (AB 1/2/4-fold evaluation or pulse and direction)
- Comparison value, set value, input filter, reset
- Interrupt and diagnostics function with  $\mu$ s time stamp
- $\mu$ s time stamp for counter value (e.g. for speed calculation)

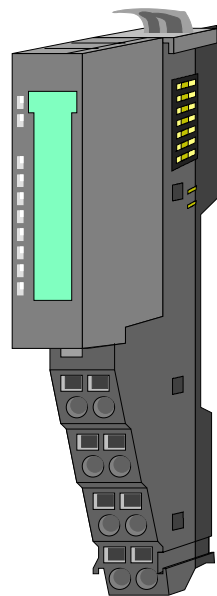

### Order data

Type	Order number	Description
FM 050	VIPA 050-1BA10	Counter module 5V differential 1x32Bit

## Structure

### 050-1BA10

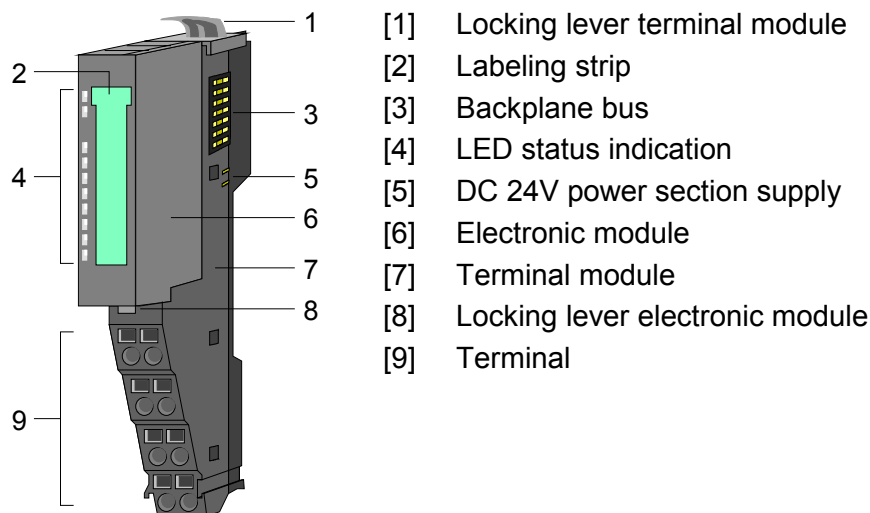

### Status indication

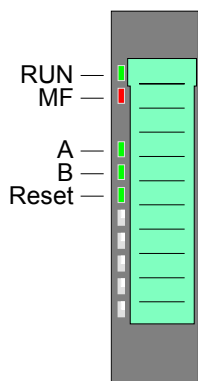

LED	Color	Description	
RUN	green	<b>RUN</b>	<b>MF</b>
MF	red	●	○
		●	●
		○	●
		○	○
		☼	☼
A	green	●	Inputs 1, 5 A/pulse are set
B	green	●	Inputs 4, 8 B/direction are set
Reset	green	●	Inputs 6, 7 Reset are set

on: ● off: ○ blinks with 2Hz: ☼

Pin assignment

For wires with a cross section of 0.08mm<sup>2</sup> up to 1.5mm<sup>2</sup>.

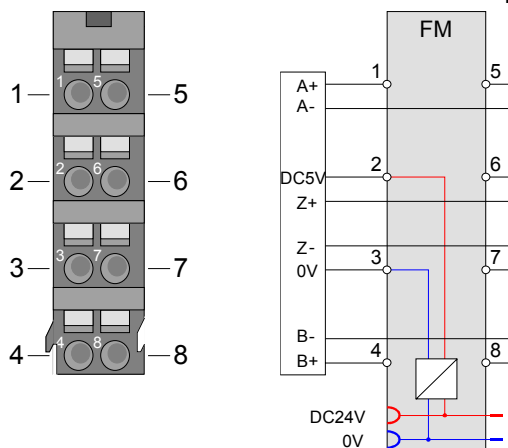

Pos.	Function	Type	Description
1	A+	I	A / pulse Difference input for counter signal res. track A of an encoder for 1-, 2- or 4-fold evaluation
2	DC 5V	O	DC 5V for encoder
3	0V	O	GND
4	B+	I	B / direction Difference input for direction signal res. track B of an encoder (invertible via parameterization)
5	A-	I	A / pulse Difference input for counter signal res. track A of an encoder for 1-, 2- or 4-fold evaluation
6	Z+	I	Difference input for Reset
7	Z-	I	Difference input for Reset
8	B-	I	B / direction Difference input for direction signal res. track B of an encoder (invertible via parameterization)

I: Input, O: Output

## Technical Data

Order number	050-1BA10
Type	FM 050
Module ID	08C2 3801
Current consumption/power loss	
Current consumption from backplane bus	75mA
Power loss	0.85W
Technical data digital inputs	
Number of inputs	-
Cable length, shielded	-
Current consumption from load voltage L+ (without load)	20mA
Nominal value	DC 20.4...28.8V
Input voltage for signal "1"	-
Input voltage for signal "0"	-
Input current for signal "1"	3mA
Connection of Two-Wire-BERO possible	-
max. permissible BERO quiescent current	-
Input delay of "0" to "1"	-
Input delay of "1" to "0"	-
Number of simultaneously utilizable horizontal	-
Number of simultaneously utilizable vertical	-
Input characteristic	-
Input data size	-
Technical data digital outputs	
Number of outputs	-
Cable length, shielded	-
Cable length, unshielded	-
Rated load voltage	-
Output delay of "0" to "1"	-
Output delay of "1" to "0"	-
Lamp load	-
Parallel switching of outputs for redundant control of a load	-
Parallel switching of outputs for increased power	-
Actuation of digital input	-
Switching frequency with resistive load	-
Switching frequency with inductive load	-
Switching frequency on lamp load	-
Internal limitation of inductive shut-off voltage	-
Short-circuit protection of output	-
Trigger level	-
Output data size	10Byte
Technical data Counters	
Number of counters	1
Counter width per counter	32Bit
maximum input frequency	500kHz
Maximum count frequency	2MHz
Mode incremental encoder	✓
Mode pulse/direction	✓
Gate input available	-
Latch input available	-
Reset input available	✓
Counter output available	-

Order number	050-1BA10
Status information, alarms, diagnostics	
Status display	yes
Interrupts	yes
Process alarm	yes
Diagnostic interrupt	yes
Diagnostic functions	yes
Diagnostics information read-out	possible
Module state	green LED
Module error display	red LED
Channel error display	none
Isolation	
Between channels and backplane bus	✓
Insulation tested with	DC 500V
Mechanical Data	
Dimensions (WxHxD)	12.9mm x 109mm x 76.5mm
Weight	60g
Environmental conditions	
Operating temperature	0°C to 60°C
Storage temperature	-25°C to 70°C
Certifications	
UL508 certifications	in preparation



# Chapter 3 Deployment

**Overview** In this chapter the deployment of the System SLIO counter module 050-1BA10 is described. Here every information required for the deployment may be found.

<b>Content</b>	<b>Topic</b>	<b>Page</b>
	<b>Chapter 3 Deployment .....</b>	<b>3-1</b>
	Fast introduction.....	3-2
	In-/Output area .....	3-5
	Parameter data .....	3-7
	Counter functions .....	3-10
	Counter additional functions .....	3-16
	Diagnostic and interrupt.....	3-21

## Fast introduction

### Counter range

Limits	Valid range of values
Lower counter limit	-2 147 483 648 ( $-2^{31}$ )
Upper counter limit	+2 147 483 647 ( $2^{31}-1$ )

The maximum counter frequency is 2MHz.

### Address area

At CPU, Profibus and ProfiNET the input respectively out area is embedded to the corresponding address area.

IX = Index for access via CANopen

SX = Subindex for access via EtherCAT

#### Input area

Addr.	Name	Bytes	Function	IX	SX
+0	CV_I	4	Counter value	5400h	01h
+4	CSTS_I	2	Counter status	5402h	02h
+6	C_US	2	16bit $\mu$ s value	5403h	03h

#### Output area

Addr.	Name	Bytes	Function	IX	SX
+0	CC_I	4	Comparison value	5600h	01h
+4	CS_I	4	Set value	5601h	02h
+8	CCTRL_I	2	Control word	5602h	03h

CSTS\_I  
Counter status

Bit	Name	Function
0	STS_SYNC	Reset was active
1	STS_CTRL_COMP	is set when <i>comparison bit</i> is enabled
2	STS_SW-GATE	Status software gate (set when <i>SW gate</i> is active)
3	STS_RST	Status reset input
4	-	reserved
5	STS_GATE	Status internal gate (set when internal gate active)
6	STS_COMP	Status <i>comparison bit</i>
7	STS_C_DN	Status set at counter direction backward
8	STS_C_UP	Status set at counter direction forward
9	STS_CMP*	Status comparison is set when the comparison condition is met. If comparison is parameterized <i>never</i> , the bit is never set
10	STS_END*	Status is set when <i>end value</i> was reached
11	STS_OFLW*	Status is set at overflow
12	STS_UFLW*	Status is set at underflow
13	STS_ZP*	Status is set at zero run
14 ... 15	-	reserved

\* The bits remain set until reset with RES\_SET (bit 6 *control word*).

CCTRL\_I  
Control word

Bit	Name	Function
0	CTRL_SYNC_SET	activates the reset mode
1	CTRL_COMP_SET	enables the <i>comparison bit</i>
2	SW_GATE_SET	sets the software gate
3	-	reserved
4	-	reserved
5	COUNTERVAL_SET	sets counter temporarily to the value of <i>set value</i>
6	RES_SET	resets the bits STS_CMP, STS_END, STS_OFLW, STS_UFLW and STS_ZP with edge 0-1
7	-	reserved
8	CTRL_SYNC_RESET	deactivates the reset mode
9	CTRL_COMP_RESET	disables the <i>comparison bit</i>
10	SW_GATE_RESET	resets the software gate
11 ... 15	-	reserved

**Parameter data** Via parameterization you may define among others:

- Interrupt behavior
- Input filter
- Counter operating mode res. behavior
- *Load value and end value*

DS = Data set for access via CPU, Profibus and ProfiNET

IX = Index for access via CANopen

SX = Subindex for access via EtherCAT

Name	Bytes	Function	Default	DS	IX	SX
DIAG_EN	1	Diagnostic interrupt*	00h	00h	3100h	01h
CH0A	1	Input frequency track A	02h	01h	3101h	02h
CH1B	1	Input frequency track B	02h	01h	3102h	03h
CH2R	1	Input frequency Reset	02h	01h	3103h	04h
CH3	1	reserved	00h	01h	3104h	05h
INT_I	1	Interrupt behavior	00h	80h	3105h	06h
FCT_I	1	Counter function	00h	80h	3106h	07h
MODE2_I	1	Counter mode 2	00h	80h	3107h	08h
MODE3_I	1	Counter mode 3	00h	80h	3108h	09h
END_I	4	End value	00h	81h	3109h...310Ch	0Ah
LOAD_I	4	Load value	00h	81h	310Dh...3110h	0Bh
HYST_I	1	Hysteresis	00h	81h	3111h	0Ch
CRES	1	reserved	00h	81h	3112h	0Dh

\* This parameter may only be transferred at STOP state.

**Control counter** The counter is controlled via the internal gate (I gate). The I gate corresponds to the software gate (SW gate).

SW gate: Open (activate): in user program by edge 0-1 of SW\_GATE\_SET in the *control word*.

Close (deactivate): in user program by edge 0-1 of SW\_GATE\_RESET in the *control word*.

**Comparison bit** The following behavior for the *comparison bit* STS\_COMP in the *counter status* may be set via the parameterization:

- No comparison: *Comparison bit* is not influenced
- *Counter value* ≥ *comparison value*: *Comparison bit* is set
- *Counter value* ≤ *comparison value*: *Comparison bit* is set
- *Counter value* = *comparison value*: *Comparison bit* is set

Please consider that the *comparison bit* may only be set, when the bit STS\_CTRL\_COMP in the *counter status* is set.

## In-/Output area

### Overview

The following in-/output areas are used by the 050-1BA10:

At CPU, Profibus and ProfiNET the input respectively output area is embedded to the corresponding address area.

IX = Index for access via CANopen

SX = Subindex for access via EtherCAT

### Input area 8byte

Addr.	Name	Bytes	Function	IX	SX
+0	CV_I	4	Counter value	5400h	01h
+4	CSTS_I	2	Counter status	5402h	02h
+6	C_US	2	16bit $\mu$ s value	5403h	03h

### CV\_I Counter value

The *counter value* always contains the current value of the counter.

### CSTS\_I Counter status

Bit	Name	Function
0	STS_SYNC	Reset was active
1	STS_CTRL_DO	is set when <i>comparison bit</i> is enabled
2	STS_SW-GATE	Status software gate (set when <i>SW gate</i> is active)
3	STS_RST	Status reset input
4	-	reserved
5	STS_GATE	Status internal gate (set when internal gate active)
6	STS_COMP	Status <i>comparison bit</i>
7	STS_C_DN	Status set at counter direction backward
8	STS_C_UP	Status set at counter direction forward
9	STS_CMP*	Status comparison is set when the comparison condition is met. If comparison is parameterized <i>never</i> , the bit is never set
10	STS_END*	Status is set when <i>end value</i> was reached
11	STS_OFLW*	Status is set at overflow
12	STS_UFLW*	Status is set at underflow
13	STS_ZP*	Status is set at zero run
14 ... 15	-	reserved

\* The bits remain set until reset with RES\_SET (bit 6 *control word*).

### C\_US 16bit $\mu$ s value

In the SLIO module there is a timer ( $\mu$ s ticker). With PowerON the timer starts counting with 0. After 65535 $\mu$ s the timer starts with 0 again.

With each change of the *counter value* the timer value is stored as 16bit  $\mu$ s value together with the *counter value* in the *input area*.

**Output area  
10byte**

Addr.	Name	Bytes	Function	IX	SX
+0	CC_I	4	Comparison value	5600h	01h
+4	CS_I	4	Set value	5601h	02h
+8	CCTRL_I	2	Control word	5602h	03h

CC\_I  
Comparison value

With *comparison value* a value may be preset that may influence the *comparison bit* res. throw a process interrupt when compared with the recent *counter value*. The behavior of the *comparison bit* respectively the process interrupt may be set via the parameter MODE2\_I respectively INIT\_I.

CS\_I  
Set value

By means of the *set value* there is the possibility to preset the counter with the *set value*. The value is kept by the counter by an changing edge 0-1 of the bit COUNTERVAL\_SET in the *control word*.

CCTRL\_I  
Control word

Bit	Name	Function
0	CTRL_SYNC_SET	activates the reset mode
1	CTRL_COMP_SET	enables the <i>comparison bit</i>
2	SW_GATE_SET	sets the software gate
3 ... 4	-	reserved
5	COUNTERVAL_SET	sets counter temporarily to the value of <i>set value</i>
6	RES_SET	resets the bits STS_CMP, STS_END, STS_OFLW, STS_UFLW and STS_ZP with rising edge
7	-	reserved
8	CTRL_SYNC_RESET	deactivates the reset mode
9	CTRL_COMP_RESET	disables the <i>comparison bit</i>
10	SW_GATE_RESET	resets the software gate
11 ... 15	-	reserved

## Parameter data

### Overview

Via parameterization you may define among others:

- Interrupt behavior
- Input filter
- Counter operating mode res. behavior
- *Load value and end value*

DS = Data set for access via CPU, Profibus and ProfiNET

IX = Index for access via CANopen

SX = Subindex for access via EtherCAT

Name	Bytes	Function	Default	DS	IX	SX
DIAG_EN	1	Diagnostic interrupt*	00h	00h	3100h	01h
CH0A	1	Input frequency track A	02h	01h	3101h	02h
CH1B	1	Input frequency track B	02h	01h	3102h	03h
CH2R	1	Input frequency Reset	02h	01h	3103h	04h
CH3	1	reserved	00h	01h	3104h	05h
INT_I	1	Interrupt behavior*	00h	80h	3105h	06h
FCT_I	1	Counter function*	00h	80h	3106h	07h
MODE2_I	1	Counter mode 2*	00h	80h	3107h	08h
MODE3_I	1	Counter mode 3*	00h	80h	3108h	09h
END_I	4	End value	00h	81h	3109h...310Ch	0Ah
LOAD_I	4	Load value	00h	81h	310Dh...3110h	0Bh
HYST_I	1	Hysteresis	00h	81h	3111h	0Ch
CRES	1	reserved	00h	81h	3112h	0Dh

\* This parameter may only be transferred at STOP state.

### DIAG\_EN Diagnostic interrupt

Byte	Bit 7 ... 0
0	Diagnostic interrupt 00h = disable 40h = enable

- Here you activate res. de-activate the diagnostic function.

### CHxx Input frequency

Byte	Function	Possible values
0	Input frequency track A	00h: 500kHz      06h: 10kHz
1	Input frequency track B	01h: 300kHz      07h: 5kHz
2	Input frequency Reset	02h: 100kHz      08h: 2kHz
3	reserved	03h: 60kHz      09h: 1kHz 04h: 30kHz Other values are not permissible!

- *Input frequency* allows you to preset a filter for input track A, track B and reset. With the help of filters you may e.g. filter signal peaks at a blurred input signal.

**INT\_I**  
Interrupt behavior

Byte	Bit 7 ... 0
0	<i>Bit 5 ... 0: Interrupt behavior</i> Bit 0: 0 (fix) Bit 1: 0 (fix) Bit 2: Proc. interrupt overflow Bit 3: Proc. interrupt underflow Bit 4: Proc. interrupt <i>comparison value</i> Bit 5: Proc. interrupt <i>end value</i> <i>Bit 7 ... 6: 0 (fix)</i>

- Setting the appropriate bit activates the associated process interrupt.

**FCT\_I**  
Counter function

Byte	Bit 7 ... 0
0	<i>Bit 5 ... 0: Counter function</i> 000000b = Count endless 000001b = Once: forward 000010b = Once: backwards 000100b = Once: no main direction 001000b = Periodic: forward 010000b = Periodic: backwards 100000b = Periodic: no main direction <i>Bit 7 ... 6: 0 (fix)</i>

**MODE2\_I**  
Counter mode 2

Byte	Bit 7 ... 0
0	<i>Bit 2 ... 0: Comparison bit is set</i> (... when following condition is met) 000b = never 001b = <i>counter value</i> >= <i>comparison value</i> 010b = <i>counter value</i> <= <i>comparison value</i> 100b = <i>counter value</i> = <i>comparison value</i> <i>Bit 3: Count direction track B inverted</i> 0 = No (not inverted) 1 = Yes (inverted) <i>Bit 6 ... 4: Reset</i> 000b = de-activated 001b = high level 011b = edge 0-1 101b = edge 0-1 once <i>Bit 7: 0 (fix)</i>

- For activation of the comparison bit STS\_COMP the bit CTRL\_COMP\_SET (bit 1) of the *control word* must be set!
- For activation of reset the bit CTRL\_SYNC\_SET (bit 0) of the *control word* must be set!



**MODE3\_I**  
**Counter mode 3**

Byte	Bit 7 ... 0
0	<i>Bit 2 ... 0: Signal evaluation</i> 000b = Counter de-activated 001b = Rotary encoder single (at A and B) 010b = Rotary encoder double (at A and B) 011b = Rotary encoder quadruple (at A and B) 100b = Direction (pulse at A and direction at B) <i>Bit 6 ... 3: 0 (fix)</i> <i>Bit 7: Gate function (internal gate)</i> 0 = abort 1 = interrupt

- At de-activated counter the further parameter settings are ignored.
- With gate function "abort" counting begins again at the load value. With "interrupt" counting is continued with the count.

**END\_I, LOAD\_I**  
**End value,**  
**Load value**

You may set an upper and a lower limit by setting a *load value* as start and an *end value*.

**HYST\_I**  
**Hysteresis**

The *hysteresis* serves the avoidance of many toggle processes of the *comparison bit* and the interrupt, if the *counter value* is in the range of the *comparison value*. You may set a range of 0 to 255. The settings 0 and 1 deactivate the *hysteresis*. The *hysteresis* influences zero run, comparison, over- and underflow.

## Counter functions

### Overview

You may count forward and backwards and choose between the following counter functions:

- Count endless, e.g. distance measuring with incremental encoder
- Count once, e.g. count to a maximum limit
- Count periodic, e.g. count with repeated counter process

In the operating modes "Count once" and "Count periodic" you may define a counter range as start and end value via the parameterization.

For every counter additional parameterizable functions are available like gate function, comparison, hysteresis and process interrupt.

### Main counting direction

Via the parameterization you have the opportunity to define a main counting direction for every counter.

If "none" is chosen, the complete counting range is available:

Limits	Valid value range
Lower count limit	-2 147 483 648 ( $-2^{31}$ )
Upper count limit	+2 147 483 647 ( $2^{31}-1$ )

#### *Main counting direction forward*

Upper restriction of the count range. The counter counts 0 res. *load value* in positive direction until the parameterized *end value* -1 and jumps then back to the *load value* with the next following encoder pulse.

#### *Main counting direction backwards*

Lower restriction of the count range. The counter counts from the parameterized start- res. *load value* in negative direction to the parameterized *end value* +1 and jumps then back to the start value with the next following encoder pulse.

### Gate function abort/interrupt

#### *Abort count process*

The count process starts after closing and restart of the gate beginning with the *load value*.

#### *Interrupt count process*

The count process continuous after closing and restart of the gate beginning with the last recent counter value.

**Count continuously**

In this operating mode, the counter counts from the *load value*.

When the counter counts forward and reaches the upper count limit and another counting pulse in positive direction arrives, it jumps to the lower count limit and counts from there on.

When the counter counts backwards and reaches the lower count limit and another counting pulse in negative direction arrives, it jumps to the upper count limit and counts from there on.

The count limits are set to the maximum count range.

Limits	Valid value range
Lower count limit	-2 147 483 648 ( $-2^{31}$ )
Upper count limit	+2 147 483 647 ( $2^{31}-1$ )

With overflow or underflow the status bits STS\_OFLW respectively STS\_UFLW are set. These bits remain set until these are reset with RES\_SET in the *control word*.

If enabled additionally a process interrupt is triggered.

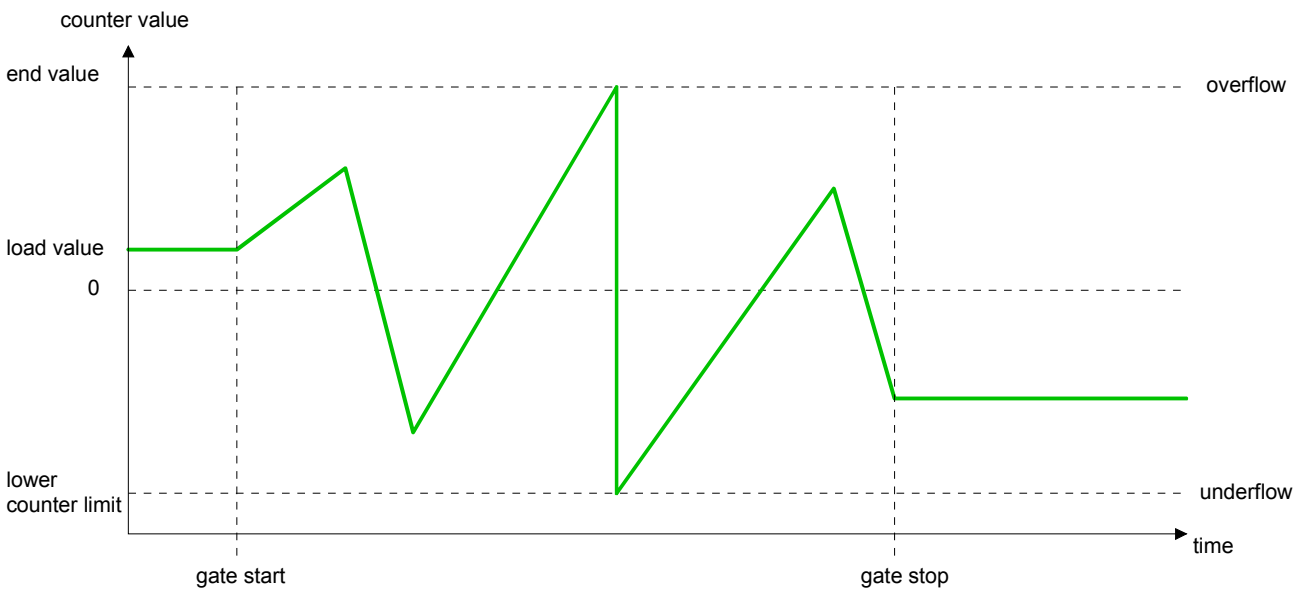

**Count Once**

*No main counting direction*

- The counter counts once starting with the *load value*.
- You may count forward or backwards.
- The count limits are set to the maximum count range.
- At over- or underflow at the count limits, the counter jumps to the according other count limit and the internal gate is automatically closed and the status bits STS\_OFLW respectively STS\_UFLW are set. If enabled additionally a process interrupt is triggered.
- To restart the count process, you have to re-open the internal gate.
- At interrupting gate control, the count process continuous with the last recent *counter value*.
- At aborting gate control, the counter starts with the *load value*.

Limits	Valid value range
Lower count limit	-2 147 483 648 ( $-2^{31}$ )
Upper count limit	+2 147 483 647 ( $2^{31}-1$ )

*Interrupting gate control:*

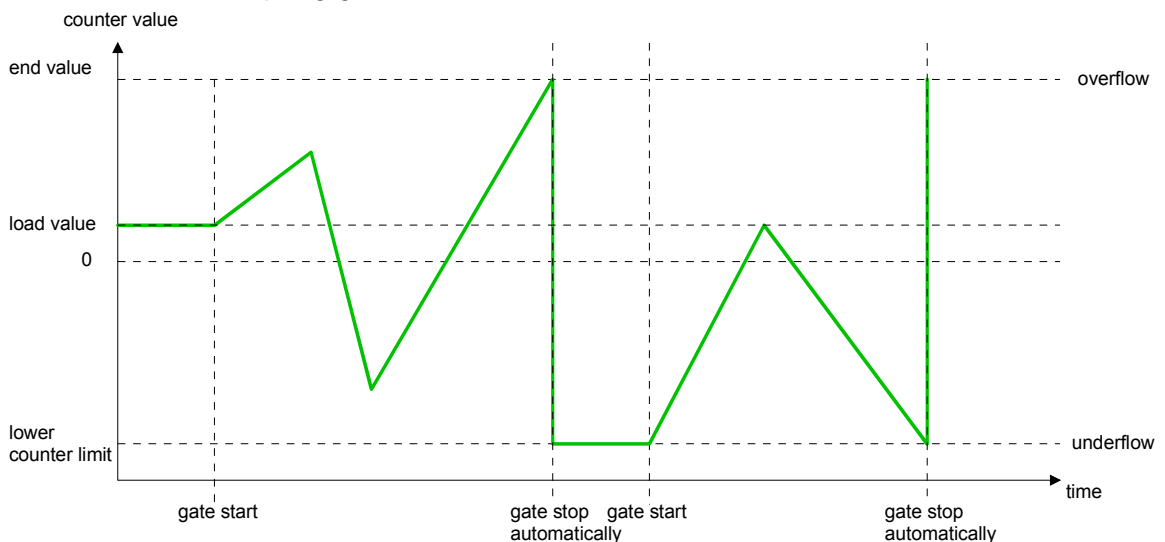

*Aborting gate control:*

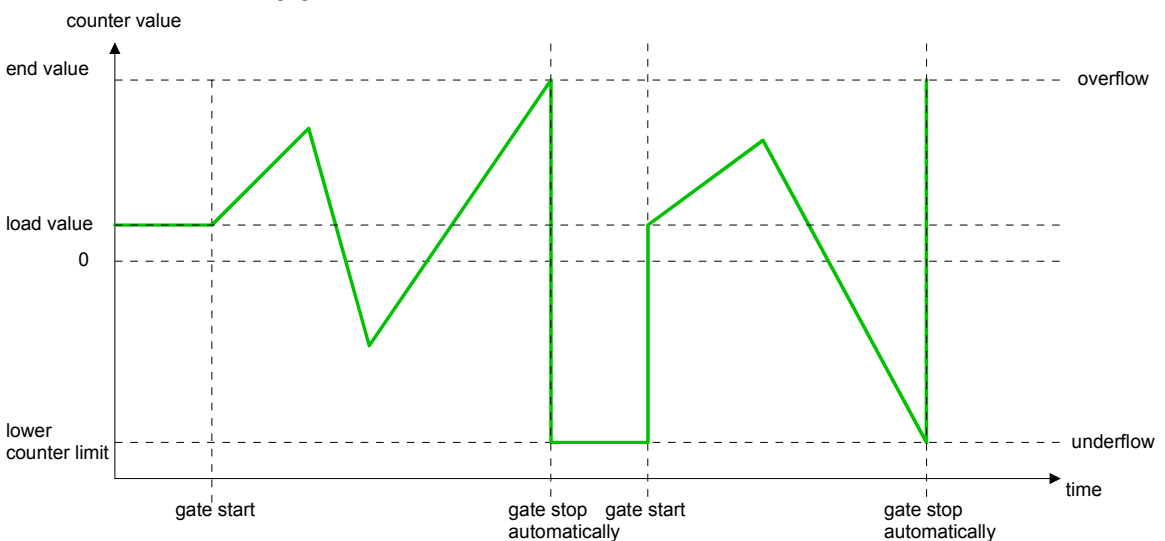

*Main counting direction forward*

- The counter counts starting with the *load value*.
- When the counter reaches the *end value* -1 in positive direction, it jumps to the *load value* at the next positive count pulse and the internal gate is automatically closed. If enabled additionally a process interrupt is triggered.
- To restart the count process, you must re-open the internal gate. The counter starts with the *load value*.
- You may count beyond the lower counter limit.

Limits	Valid value range
Limit value	-2 147 483 646 ( $-2^{31}+1$ ) to +2 147 483 646 ( $2^{31}-1$ )
Lower count limit	-2 147 483 648 ( $-2^{31}$ )

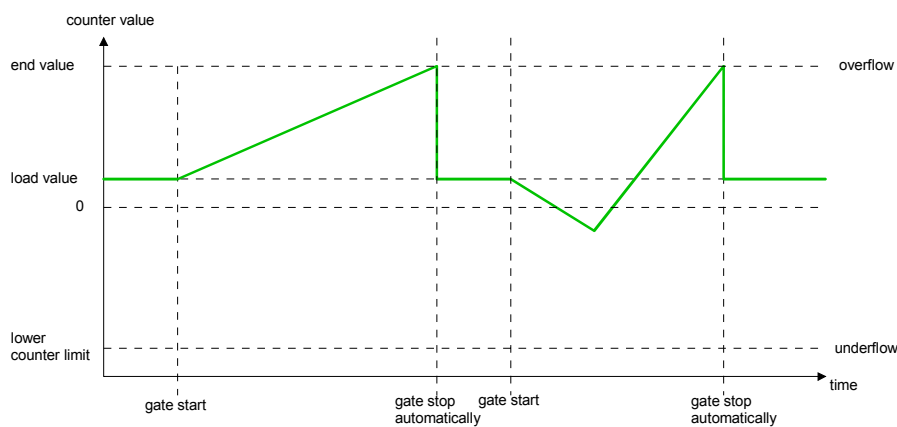

*Main counting direction backwards*

- The counter counts backwards starting with the *load value*.
- When the counter reaches the *end value* +1 in negative direction, it jumps to the *load value* at the next negative count pulse and the gate is automatically closed. If enabled additionally a process interrupt is triggered.
- To restart the count process, you must create an edge 0-1 of the gate. The counter starts with the *load value*.
- You may count beyond the upper counter limit.

Limits	Valid value range
Limit value	-2 147 483 646 ( $-2^{31}+1$ ) to +2 147 483 646 ( $2^{31}-1$ )
Upper count limit	+2 147 483 646 ( $2^{31}-1$ )

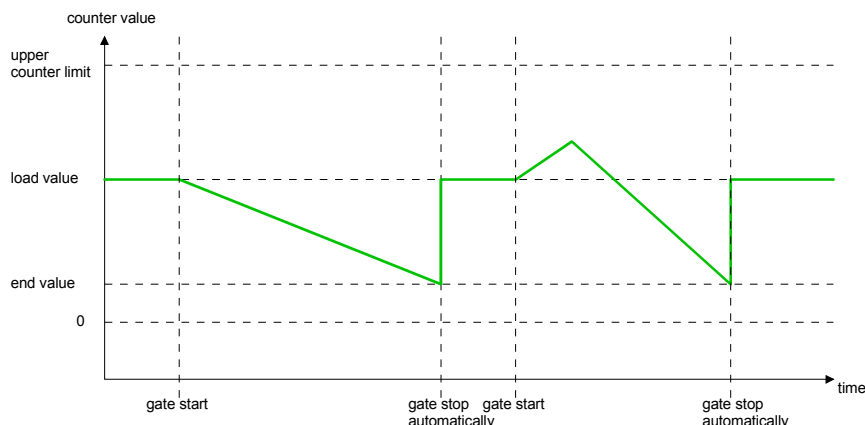

**Count Periodically** *No main counting direction*

- The counter counts forward or backwards starting with the *load value*.
- At over- or underflow at the count limits, the counter jumps to the *load value* and counts from there on. If enabled additionally a process interrupt is triggered.
- The count limits are set to the maximum count range.

Limits	Valid value range
Lower count limit	-2 147 483 648 ( $-2^{31}$ )
Upper count limit	+2 147 483 647 ( $2^{31}-1$ )

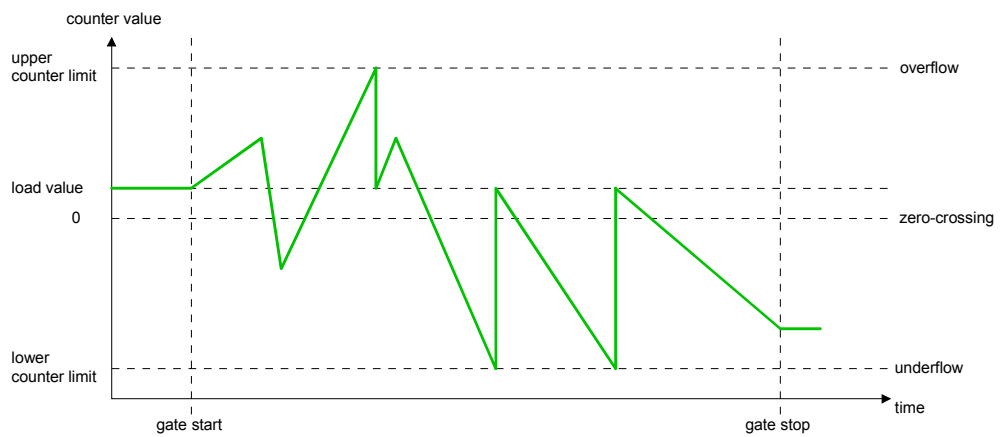

*Main counting direction forward*

- The counter counts forward starting with the *load value*.
- When the counter reaches the *end value* -1 in positive direction, it jumps to the *load value* at the next positive count pulse. If enabled additionally a process interrupt is triggered.
- You may count beyond the lower counter limit.

Limits	Valid value range
Limit value	-2 147 483 647 ( $-2^{31}+1$ ) to +2 147 483 647 ( $2^{31}-1$ )
Lower count limit	-2 147 483 648 ( $-2^{31}$ )

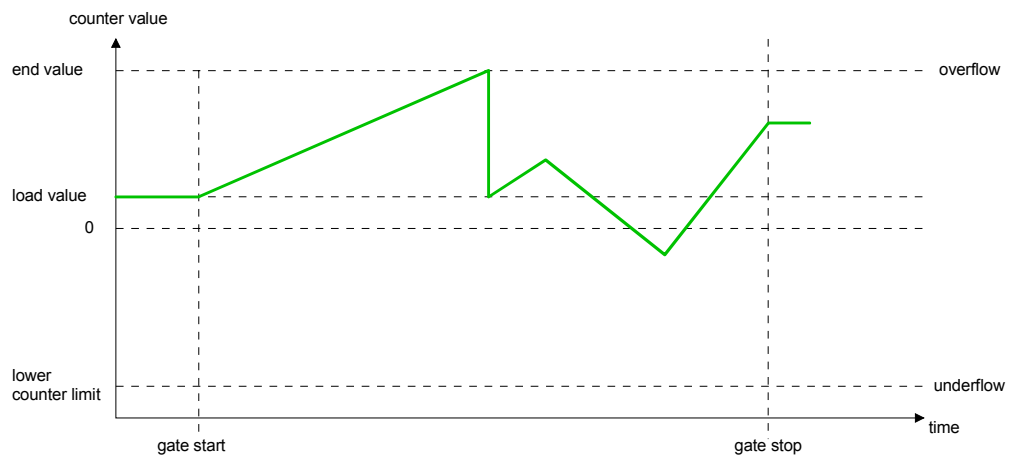

*Main counting direction backwards*

- The counter counts backwards starting with the *load value*.
- When the counter reaches the *end value* +1 in negative direction, it jumps to the *load value* at the next negative count pulse. If enabled additionally a process interrupt is triggered.
- You may exceed the upper count limit.

Limits	Valid value range
Limit value	-2 147 483 647 ( $-2^{31}+1$ ) to +2 147 483 647 ( $2^{31}-2$ )
Upper count limit	+2 147 483 647 ( $2^{31}-1$ )

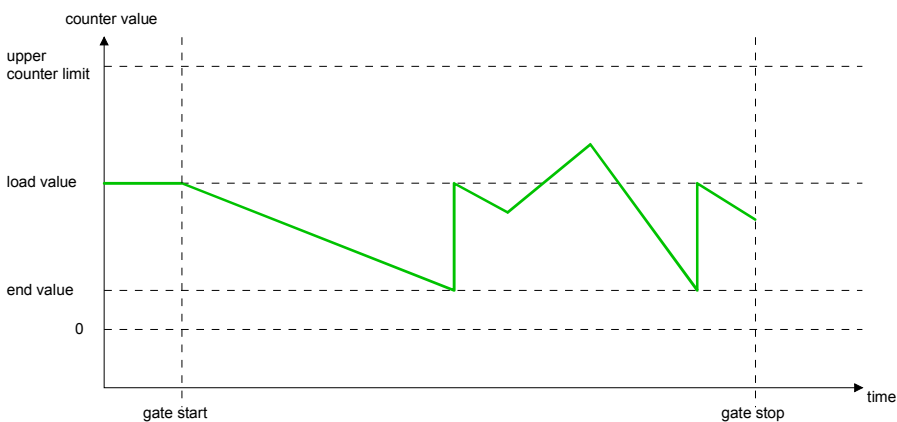

## Counter additional functions

### Overview

The following additional functions may be set for each counter via the parameterization:

- Gate function

The gate function serves for the start, stop and interrupt of a count function.

- Comparison

You may set a *comparison value* that activates res. de-activates the digital output res. releases a process interrupt depending on the *counter value*.

- Hysteresis

The setting of a *hysteresis* avoids for example a high interrupt toggling when the value of an encoder signal shifts around a *comparison value*.

### Schematic structure

The illustration shows how the additional functions influence the counting behavior. The following pages describe these functions in detail:

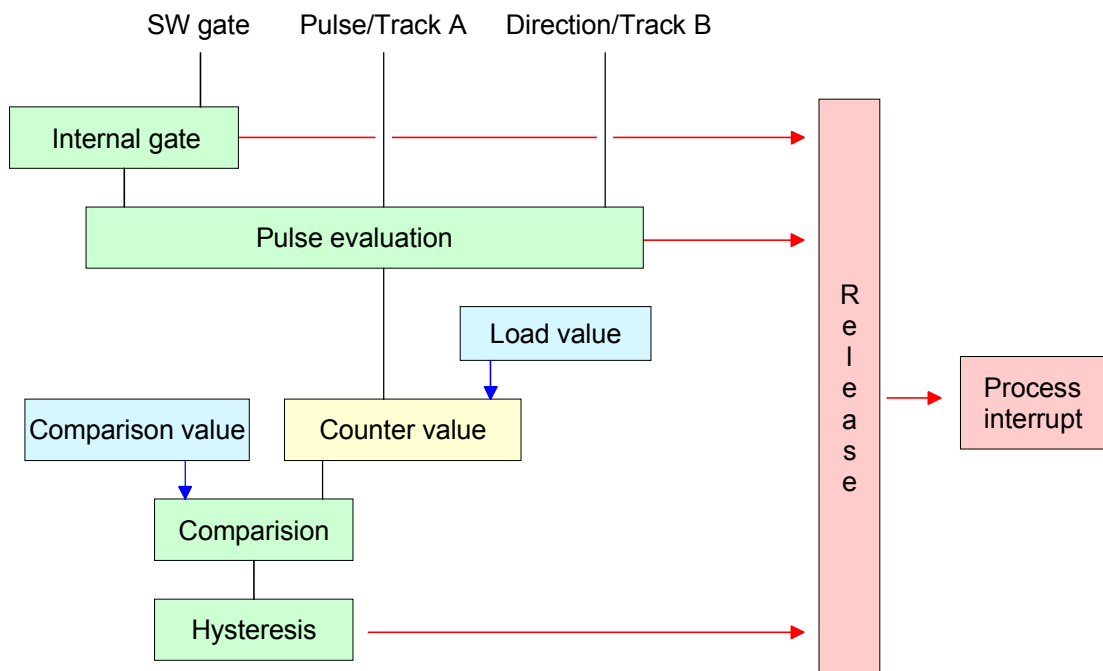



**Gate function**

The activation res. de-activation of the counter happens via an internal gate (I gate). The I gate corresponds to the software gate (SW gate).

The SW gate is opened (activated) via your user application by an edge 0-1 of the bit SW\_GATE\_SET of the control word in the output area. The software gate is closed (de-activated) by an edge 0-1 of the bit SW\_GATE\_RESET. If the I gate was automatically closed at "counting once", so this may only be opened with an edge 0-1 on SW\_GATE\_SET.

The following states influence the I gate:

SW gate	influences I gate
0	0
1	1
with edge 0-1	1

*Gate function abort and interrupt*

The parameterization defines if the gate interrupts or aborts the counter process.

- At *abort function* the counter starts counting with the load value after gate restart.

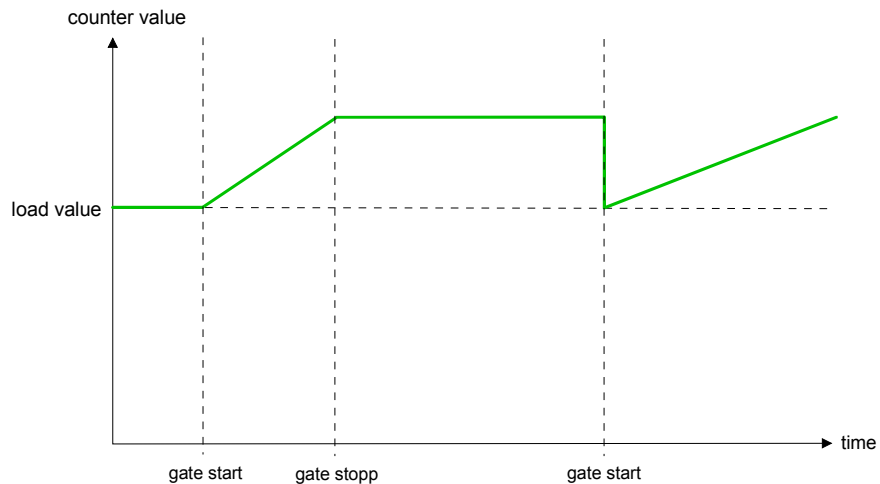

- At *interrupt function*, the counter starts counting with the recent counter value after gate restart.

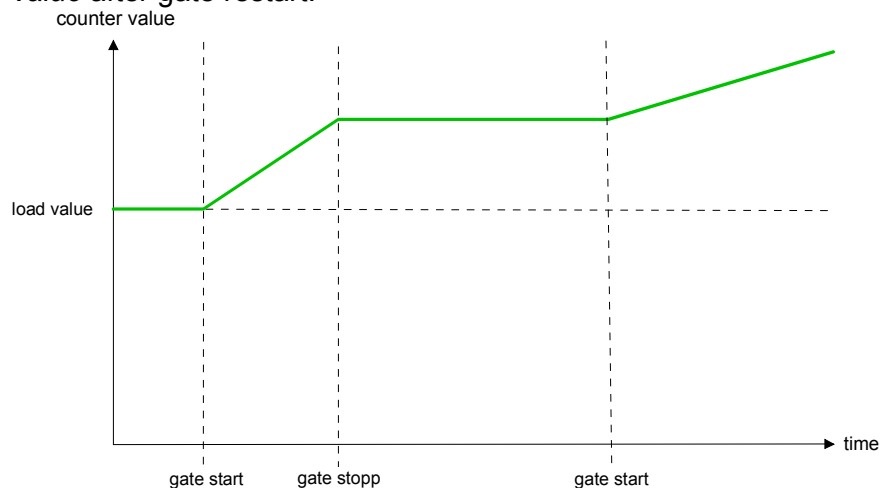

**Comparison function**

The *compare value* is to be pre-defined by the *output area*. The *comparison bit* may be found at the *counter status* at STS\_COMP.

Please consider that the bit STS\_COMP may only be influenced when in the *counter status* the bit STS\_CTRL\_COMP is set.

The following behavior for the *comparison bit* may be pre-defined via the parameterization:

- no comparison: *Comparison bit* is not influenced
- *Counter value*  $\geq$  *comparison value*: *comparison bit* is set
- *Counter value*  $\leq$  *comparison value*: *comparison bit* is set
- *Counter value* = *comparison value*: *comparison bit* is set

*no comparison*

The *comparison bit* is not influenced.

*Comparison bit is set when counter value  $\geq$  comparison value*

The *comparison bit* remains set as long as the *counter value* is higher or equal *comparison value*.

*Comparison bit is set when counter value  $\leq$  comparison value*

The *comparison bit* remains set as long as the *counter value* is lower or equal *comparison value*.

*Comparison bit is set when counter value = comparison value*

When the counter reaches the *comparison value* the *comparison bit* is set. The *comparison bit* remains set as long as the comparison condition is met.

When you've set a main counting direction the *comparison bit* is only set at reaching the *comparison value* from the main counting direction.

**Note!**

The bit STS\_COMP is set together with the bit STS\_CMP in the *counter status*. In contrast to the bit STS\_COMP this bit remains set as long as it is reset by setting the bit RES\_SET in the *control word*.

## Hysteresis

The *hysteresis* serves e.g. the avoidance of many toggle processes of the interrupt, if the *counter value* is in the range of the *comparison value*. You may set a range of 0 to 255. The settings 0 and 1 deactivate the *hysteresis*. The *hysteresis* influences the zero run, over-/underflow and *comparison value*.

An activated *hysteresis* remains active after a change. The new *hysteresis* range is taken over at the next *hysteresis* event.

The following pictures illustrate the behavior of the comparison bit for *hysteresis 0* and *hysteresis 3* for the according conditions:

### Effect at counter value $\geq$ comparison value

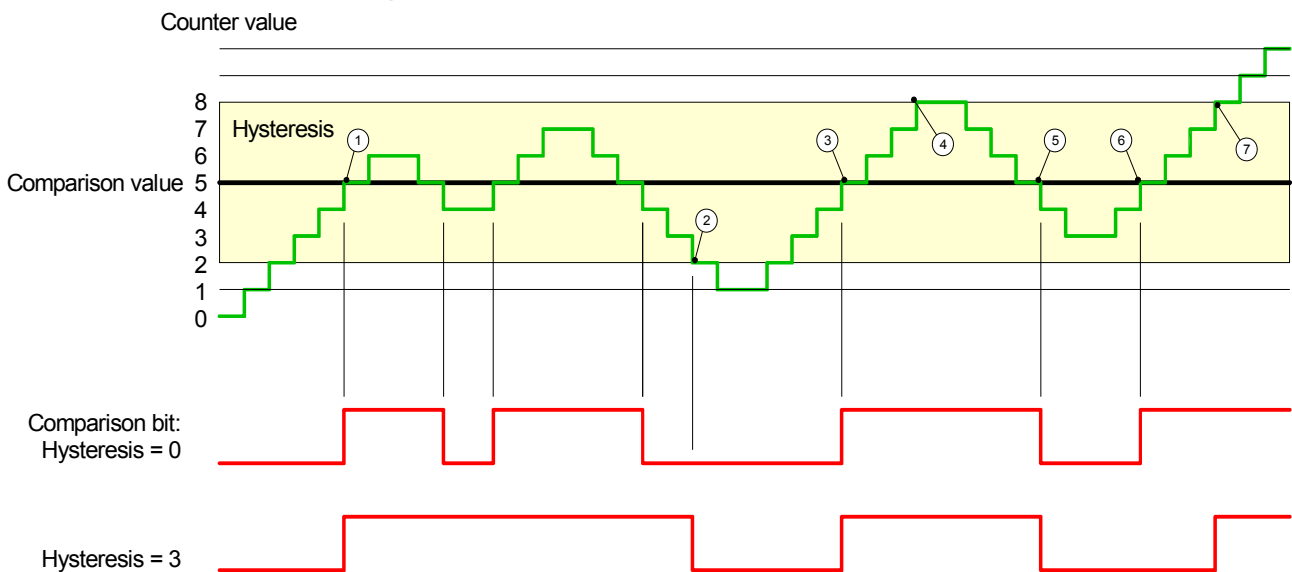

- (1) Counter value  $\geq$  comparison value  $\rightarrow$  comparison bit is set and hysteresis activated
- (2) Leave hysteresis range  $\rightarrow$  comparison bit is reset
- (3) Counter value  $\geq$  comparison value  $\rightarrow$  comparison bit is set and hysteresis activated
- (4) Leave hysteresis range, comparison bit remains set for counter value  $\geq$  comparison value
- (5) Counter value  $<$  comparison value and hysteresis active  $\rightarrow$  comparison bit is reset
- (6) Counter value  $\geq$  comparison value  $\rightarrow$  comparison bit is not set for hysteresis active
- (7) Leave hysteresis range, comparison bit remains set for counter value  $\geq$  comparison value

With reaching the comparison condition the *hysteresis* gets active. At active *hysteresis* the comparison result remains unchanged until the *counter value* leaves the set *hysteresis* range. After leaving the *hysteresis* range a new *hysteresis* is only activated with again reaching the comparison conditions.

Effect at counter value = comparison value

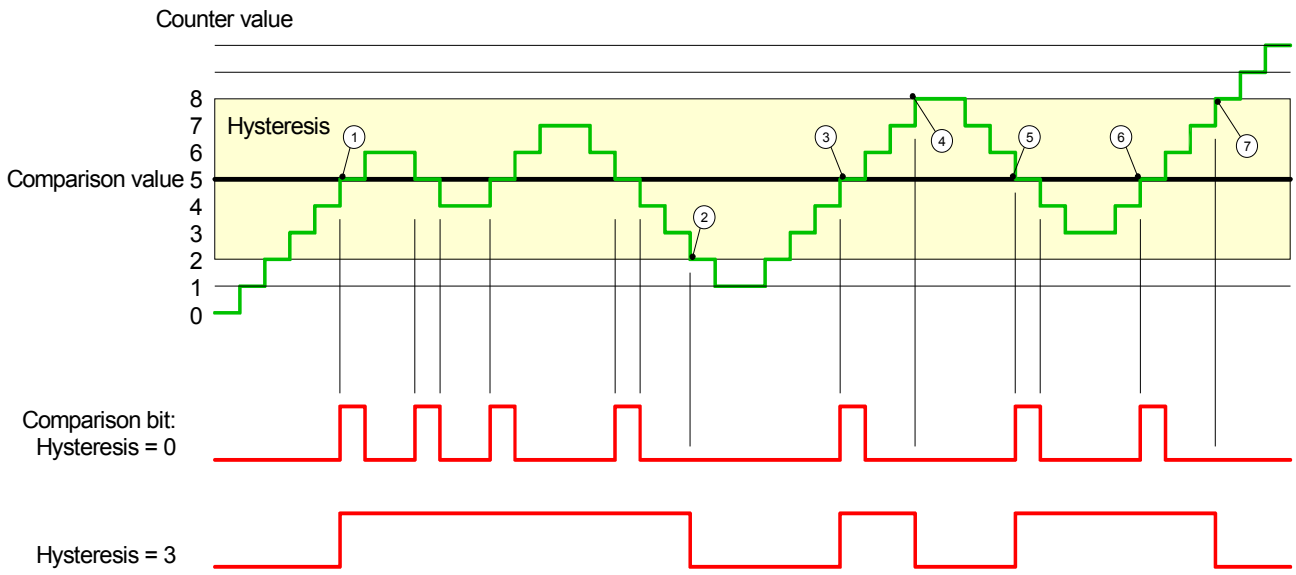

- (1) Counter value = comparison value → comparison bit is set and hysteresis activated
- (2) Leave hysteresis range → comparison bit is reset and Counter value < comparison value
- (3) Counter value = comparison value → comparison bit is set and hysteresis activated
- (4) Comparison bit is reset for leaving hysteresis range and counter value > comparison value
- (5) Counter value = comparison value → comparison bit is set and hysteresis activated
- (6) Counter value = comparison value and hysteresis active → comparison bit remains set
- (7) Leave hysteresis range and counter value ≥ comparison value → comparison bit is reset

With reaching the comparison condition the *hysteresis* gets active. At active *hysteresis* the comparison result remains unchanged until the *counter value* leaves the set *hysteresis* range. After leaving the *hysteresis* range a new *hysteresis* is only activated with again reaching the comparison conditions.

## Diagnostic and interrupt

### Overview

Event	Process interrupt	Diagnostics interrupt	parameterizable
Overflow	X	-	X
Underflow	X	-	X
Comparison value	X	-	X
End value	X	-	X
Process interrupt lost	-	X	X
Power supply is * missing	-	X	X

\* The module may only send a diagnostic interrupt if at the time of power loss the diagnostic interrupt was already enabled. If the power supply is already missing during startup (diagnostic interrupt is off), no diagnostic interrupt may be sent.

### Process interrupt

So you may react to asynchronous events, there is the possibility to activate a process interrupt. A process interrupt interrupts the linear program sequence and jumps depending on the master system to a corresponding Interrupt routine. Here you can react to the process interrupt accordingly.

With CANopen the process interrupt data are transferred via an emergency telegram. Operating with CPU, Profibus and ProfiNET the process interrupt data were transferred via diagnostics telegram.

SX = Subindex for access via EtherCAT.

Name	Bytes	Function	Default	SX
PRIT_A	1	Process interrupt data	00h	02h
PRIT_B	1	State of the inputs	00h	03h
PRIT_US	2	µs ticker	00h	04h ... 05h

PRIT\_A  
Process interrupt data

Byte	Bit 7 ... 0
0	Process interrupt data Bit 1 ... 0: reserved Bit 2: Overflow, underflow or end value reached Bit 3: Comparison value reached Bit 7 ... 4 reserved

PRIT\_B  
State of the inputs

Byte	Bit 7 ... 0
0	State of the inputs at the moment of the process interrupt Bit 0: Input value channel 0 (Track A) Bit 1: Input value channel 1 (Track B) Bit 2: Input value channel 2 (Reset) Bit 7 ... 3 reserved

PRIT\_US  
µs ticker

Byte	Bit 7 ... 0
0 ... 1	Value of the µs ticker at the moment of the process interrupt

**Diagnostic data**

Via the parameterization you may activate a diagnostic interrupt for the module.

With a diagnostic interrupt the module serves for diagnostic data for diagnostic interrupt<sub>t<sub>incoming</sub></sub>.

As soon as the reason for releasing a diagnostic interrupt is no longer present, the diagnostic interrupt<sub>t<sub>going</sub></sub> automatically takes place.

All events of a channel between diagnostic interrupt<sub>t<sub>incoming</sub></sub> and diagnostic interrupt<sub>t<sub>going</sub></sub> are not stored and get lost.

Within this time window (1. diagnostic interrupt<sub>t<sub>incoming</sub></sub> until last diagnostic interrupt<sub>t<sub>going</sub></sub>) the MF-LED of the module is on.

DS = Record set for access via CPU, Profibus and ProfiNET. The access happens by DS 01h. Additionally the first 4 bytes may be accessed by DS 00h.

IX = Index for access via CANopen. The access happens by IX 2F01h. Additionally the first 4 bytes may be accessed by IX 2F00h.

SX = Subindex for access via EtherCAT.

Name	Bytes	Function	Default	DS	IX	SX
ERR_A	1	Diagnostic	00h	01h	2F01h	02h
MODTYP	1	Module information	18h			03h
ERR_C	1	reserved	00h			04h
ERR_D	1	Diagnostic	00h			05h
CHTYP	1	Channel type	76h			06h
NUMBIT	1	Number diagnostics bits per channel	08h			07h
NUMCH	1	Number channels of the module	01h			08h
CHERR	1	Channel error	00h			09h
CH0ERR	1	Channel-specific error	00h			0Ah
CH1ERR... CH7ERR	7	reserved	00h			0Bh ... 11h
DIAG_US	4	µs ticker	00h			12h

ERR\_A  
Diagnostic

Byte	Bit 7 ... 0
0	Bit 0: set at module failure Bit 1: set at internal error Bit 2: set at external error Bit 3: set at channel error Bit 4: set at missing external power supply Bit 7 ... 5: reserved

MODTYP  
Modul information

Byte	Bit 7 ... 0
0	Bit 3 ... 0: Module class 1000b: Function module Bit 4: set at channel information present Bit 7 ... 5: reserved

ERR\_C  
reserved

Byte	Bit 7 ... 0
0	reserved

ERR_D Diagnostic	Byte	Bit 7 ... 0
	0	Bit 5 ... 0: reserved Bit 6: set at process interrupt lost Bit 7: reserved

CHTYP Channel type	Byte	Bit 7 ... 0
	0	Bit 6 ... 0: Channel type 76h: Counter module Bit 7: reserved

NUMBIT Diagnostic bits	Byte	Bit 7 ... 0
	0	Number of diagnostics bits of the module per channel(here 08h)

NUMCH Channels	Byte	Bit 7 ... 0
	0	Number of channels of the module (here 01h)

CHERR Channel error	Byte	Bit 7 ... 0
	0	Bit 0: set at error in channel group 0 Bit 7 ... 1: reserved

CH0ERR Channel-specific	Byte	Bit 7 ... 0
	0	Diagnostic interrupt due to process interrupt lost at ... Bit 1 ... 0: reserved Bit 2: Overflow/underflow/end value Bit 3: Comparison value reached Bit 7 ... 4: reserved

CH1ERR ... CH7ERR reserved	Byte	Bit 7 ... 0
	0	reserved

DIAG_US µs ticker	Byte	Bit 7 ... 0
	0 ... 3	Value of the µs ticker at the moment of the diagnostic

