

## Type STS 02

modular @ analyse

### Turbidity Sensor

#### Basic features

- ▶ Automatic Cleaning possible by use of Process Fitting SAW-830
- ▶ Securely Phase-Separation
- ▶ Quicker product-changes
- ▶ Reduced costs for waste water
- ▶ Filter-monitoring
- ▶ Colour-independent concentration measurement
- ▶ Compact Design with integrated electronic and display for parameterisation
- ▶ Robust saphir-windows, CIP/SIP-suitable
- ▶ Hygienic Design, elastomer-free sealing system
- ▶ LED-light, stable and durable signal guaranteed
- ▶ Integrated digital- and analog-output
- ▶ Simple parameterization
- ▶ Process-monitoring and documentation



#### Technical Features

- ▶ Measuring range 0-100%
- ▶ Wave length 880 nm
- ▶ Light source LED
- ▶ Optical pathlength 5, 10 mm
- ▶ Made of high grade steel 1.4435 (316L)
- ▶ Finish quality electropolished <math><0,37 \mu\text{m}</math> Ra
- ▶ Window: Saphir
- ▶ Supply voltage 12...30VDC
- ▶ Output current 4...20mA
- ▶ Output PNP Normally Closed / Normally open, parametrisable / 200 mA max.
- ▶ Input-contact: zero position
- ▶ Cable-Connection M12-plug, 5-pole
- ▶ Process connection PG 13,5 thread
- ▶ Ambient temperature: -20...70°C
- ▶ Process-temperature 0...90 °C, 140 °C max. for 2 hours (SIP-cycle)
- ▶ Process-pressure 10 bar (150 psig) max. at 60 °C

Foto in Prozessarmatur SAW 830



OPL 5



OPL 10

#### Favoured fields of application are:

STS is a sensor for monitoring the optical density of liquids, to control process-results continuously or to indicate changes securely. Especially suitable for phase-separation, filter-monitoring and concentration measurement.

#### ATTENTION!

At lower deviation of dew points water condensation is possible, that can destroy the sensor. At stress with change of temperatures, e. G. a cold water jet on the hot sensor, it can come to absorption of fluids in to the sensor. (Requirements cf. DIN EN 60068-2-14)  
At applications with dew point, temperature shock or thermal shock stresses we recommend to put in the enclosed silikagel-bag into the connecting head.

The tightness classification after IP68 does not mean that these parts are suitable! for applications with lower deviation of dew point or temperature shock. (DIN 60068-2-14)

## Type STS 02

modular @ analyse

### Technical Facts

Supply Voltage: 12...30 VDC  
 Current demand: ca. 80 mA (30V, Analog-Output= 22,5 mA)  
 Power Input: 2,4 W max.  
 Analog-Output: 4-20 mA  
 Current limit: 3,5 mA min.  
 Torque: 22,5 mA max., adjustable  
 10-20Nm

Load:  $\leq (U_b - 4V) / 20mA$  (max. 400 Ohm at 12V, 1000 Ohm at 24V, 1300 Ohm at 30V)  
 Teach-Input: Digital-Input, +12...30VDC, circa. 1,6mA input current  
 Switch-Output: semiconductor-switching, PNP-switching  
 Switched Power: 200mA max., thermally protected against overload  
 Protection class: IP 68

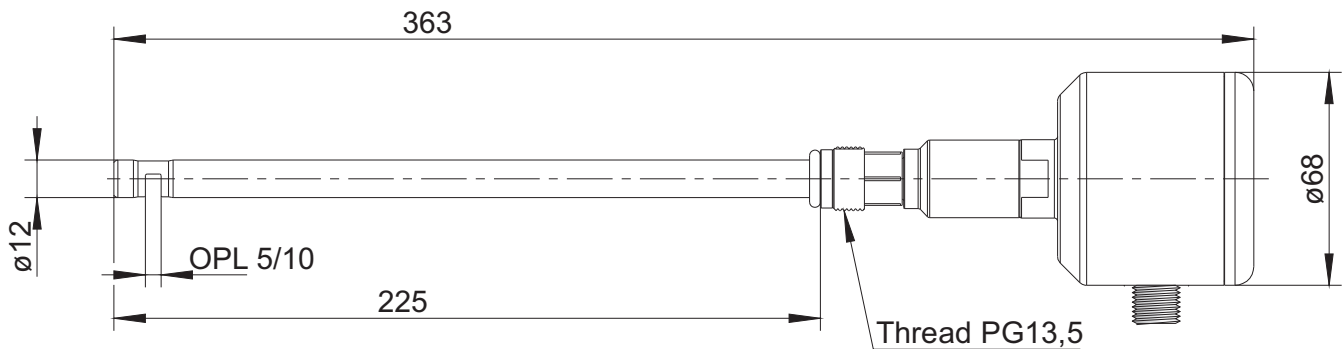

### Typical Turbidities

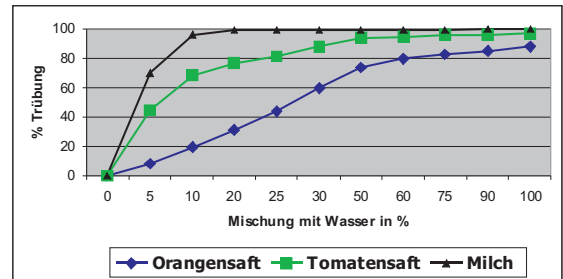
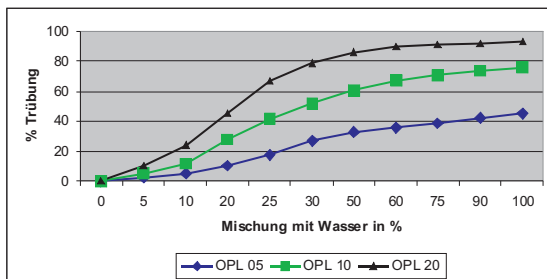

Wheat beer with different OPLs

Different products with OPL 010

### Order Code

STS 02  -  -  -

#### Optical Pathlength

Optical Pathlength 5 mm

005

Optical Pathlength 10 mm

010

#### Configuration Measuring-Range

Measuring range 0...100,0%

Special Constructions on request

1

K

#### Interface / Parameterization

4...20 mA

A

Special Constructions on request

K

#### Display / Control Unit

with integrated display

1

without Display

0

Special Constructions on request

X

### Accessories



Redox-Holder SAW-830